Introduction to Fiber Optics

Course No: E04-049

Credit: 4 PDH

Jeffrey P. Cwalinski, P.E.



Continuing Education and Development, Inc.
22 Stonewall Court
Woodcliff Lake, NJ 07677

P: (877) 322-5800
info@cedengineering.com

COURSE ERRATA

The following are corrections to the Introduction to Fiber Optics course material.

Page 4 - Figure 2-3, the word "ASSORTED" should be "ABSORBED"

Page 11 - The θ_1 should be (θ_1) and θ_2 should be (θ_2)

Page 12 - θ_1 should be (θ_1) and θ_c should be (θ_c)

Page 15 - θ_1 should be (θ_1) , θ_2 should be (θ_2) , θ_c should be (θ_c) and Figure 2-12 the I_1 should be I_2 .

Page 16 - θ_a should be (θ_a) , and "Figure 2-12 Fiber acceptance angle" should be "Figure 2-13 Fiber acceptance angle". Also, for this figure the phrase "CLADDING (n_1)" should be "CORE (n_1)".

Page 17 - The θ_a should be (θ_a)

Page 19 - "Consider the wave front incident on the core of an optical fiber as shown in figure 2-15." should be "Consider the wave front incident on the core of an optical fiber as shown in figure 2-16."

Page 20 - $\sin \theta$ should be $(\sin \theta)$

Page 24 - The "8 to 10 (m)" should be "8 to 10 (μm)", the $V < 2.405$ should be $V \leq 2.405$, the (< 1.0) should be (≤ 1.0) .

Page 25 - The "50 to 100 (m)" should be "50 to 100 (μm)"

CHAPTER 2

FIBER OPTIC CONCEPTS

LEARNING OBJECTIVES

Upon completion of this topic, you should be able to do the following:

1. Understand the nature of light propagation.
2. Discuss the electromagnetic theory of light.
3. Describe the properties of light.
4. Explain how optical fibers transmit light.
5. Identify the basic optical fiber material properties.
6. Describe the ray and mode theories of light propagation along an optical fiber.
7. State the difference between multimode and single mode optical fibers.
8. Explain how optical fibers attenuate and distort light signals as they travel along the optical fiber.
9. Understand the processes of light attenuation and dispersion.

INTRODUCTION

When you first learn of fiber optics you will come to realize it is a vast field and growing rapidly. Conceptually fiber optics is still in its infancy and developmental stages. Relatively speaking, one could compare it to the where the automobile industry or electrical power distribution was in the 1930's!

The exponential growth of this industry has skyrocketed in recent years. It shows no sign of slowing and more technology and industries are using this technology with increasing reliability at a higher level of performance every day. Some of the most obvious fields of use are communications and lighting. There have been huge gains however using fiber optics in security, medical, construction, production, advertising, transportation, art, toys and now clothing!

Let's look at just a couple examples how fiber optics can be used. Take construction for instance, today a bridge can be built having optical fiber embedded to measure the conditions of the bridge. In the medical industry fiber optic cables can be used to send signals to and from a person's brain to a prosthetic and back to give a higher quality of life. It doesn't matter what type of industry or how the fiber optics is utilized.

The technology uses the same conceptual ideas and principles for propagating the light. It is simply a matter of how the light is used and what message is being sent.

FIBER OPTIC LIGHT TRANSMISSION

Fiber optics deals with the transmission of light energy through transparent fibers. How an optical fiber guides light depends on the nature of the light and the structure of the optical fiber. A light wave is a form of energy that is moved by wave motion. Wave motion can be defined as a recurring disturbance advancing through space with or without the use of a physical medium. In fiber optics, wave motion is the movement of light energy through an optical fiber. To fully understand the concept of wave motion, refer to NEETS Module 10—Wave Propagation, Transmission Lines, and Antennas. Before we introduce the subject of light transmission through optical fibers, you must first understand the nature of light and the properties of light waves.

PROPAGATION OF LIGHT

The exact nature of light is not fully understood, although people have been studying the subject for many centuries. In the 1700s and before, experiments seemed to indicate that light was composed of particles. In the early 1800s, a physicist Thomas Young showed that light exhibited wave characteristics. Further experiments by other physicists culminated in James Clerk (pronounced Clark) Maxwell collecting the four fundamental equations that completely describe the behavior of the electromagnetic fields. James Maxwell deduced that light was simply a component of the electromagnetic spectrum. This seems to firmly establish that light is a wave. Yet, in the early 1900s, the interaction of light with semiconductor materials, called the photoelectric effect, could not be explained with electromagnetic wave theory. The advent of quantum physics successfully explained the photoelectric effect in terms of fundamental particles of energy called **quanta**. Quanta are known as **photons** when referring to light energy.

Today, when studying light that consists of many photons, as in propagation, that light behaves as a continuum—an electromagnetic wave. On the other hand, when studying the interaction of light with semiconductors, as in sources and detectors, the quantum physics approach is taken. The wave versus particle dilemma can be addressed in a more formal way, but that is beyond the scope of this text. It suffices to say that much has been reconciled between the two using quantum physics. In this manual, we use both the electromagnetic wave and photon concepts, each in the places where it best matches the phenomenon we are studying.

The electromagnetic energy of light is a form of electromagnetic radiation. Light and similar forms of radiation are made up of moving electric and magnetic forces. A simple example of motion similar to these radiation waves can be made by dropping a pebble into a pool of water, see figure 2-1. In this example, the water is not actually being moved by the outward motion of the wave, but rather by the up-and-down motion of the water. The up-and-down motion is transverse, or at right angles, to the outward motion of

the waves. This type of wave motion is called **transverse-wave motion**. The transverse waves spread out in expanding circles until they reach the edge of the pool, in much the same manner as the transverse waves of light spread from the sun. However, the waves in the pool are very slow and clumsy in comparison with light, which travels approximately 186,000 miles per second.



Figure 2-1. - Transverse wave

Light radiates from its source in all directions until it is absorbed or diverted by some substance, see figure 2-2. The lines drawn from the light source (a light bulb in this instance) to any point on one of the transverse waves indicate the direction that the wave fronts are moving. These lines are called **light rays**.

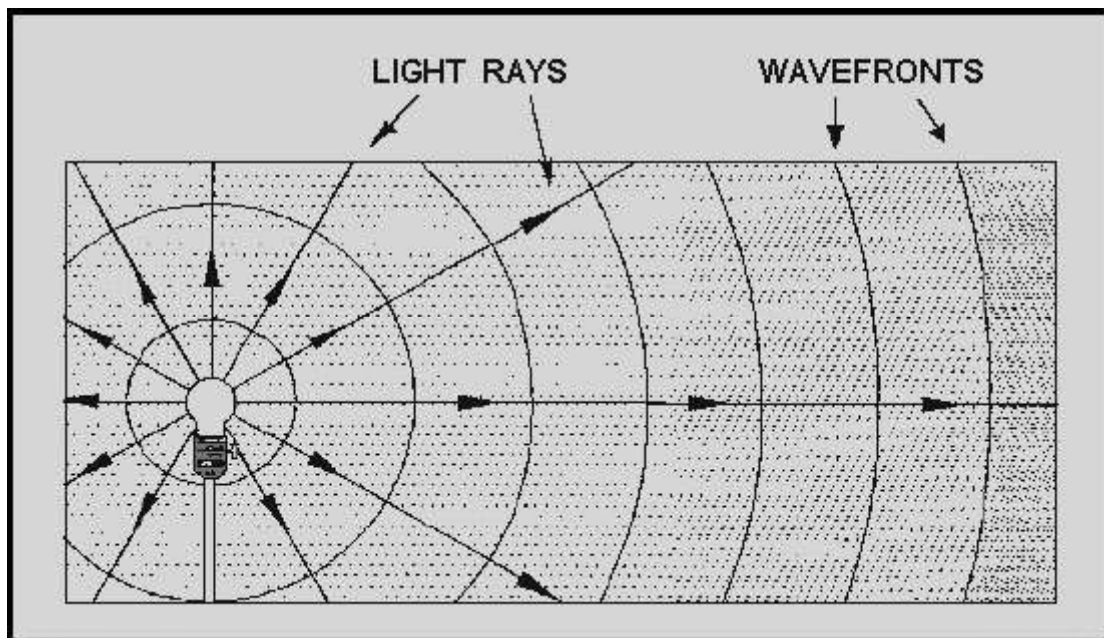

Figure 2-2. - Light rays and wave fronts from a nearby light source

Although single rays of light typically do not exist, light rays shown in illustrations are a convenient method used to show the direction in which light is traveling at any point. A ray of light can be illustrated as a straight line.

Q1. Quantum physics successfully explained the photoelectric effect in terms of fundamental particles of energy called quanta. What are the fundamental particles of energy (quanta) known as when referring to light energy?

Q2. What type of wave motion is represented by the motion of water?

PROPERTIES OF LIGHT

When light waves, which travel in straight lines, encounter any substance, they are either reflected, absorbed, transmitted, or refracted. This is illustrated in figure 2-3. Those substances that transmit almost all the light waves falling upon them are said to be **transparent**. A transparent substance is one through which you can see clearly. Clear glass is transparent because it transmits light rays without diffusing them (view A of figure 2-4). There is no substance known that is perfectly transparent, but many substances are nearly so. Substances through which some light rays can pass, but through which objects cannot be seen clearly because the rays are diffused, are called **translucent** (view B of figure 2-4). The frosted glass of a light bulb and a piece of oiled paper are examples of translucent materials. Those substances that are unable to transmit any light rays are called **opaque** (view C of figure 2-4). Opaque substances either reflect or absorb all the light rays that fall upon them.

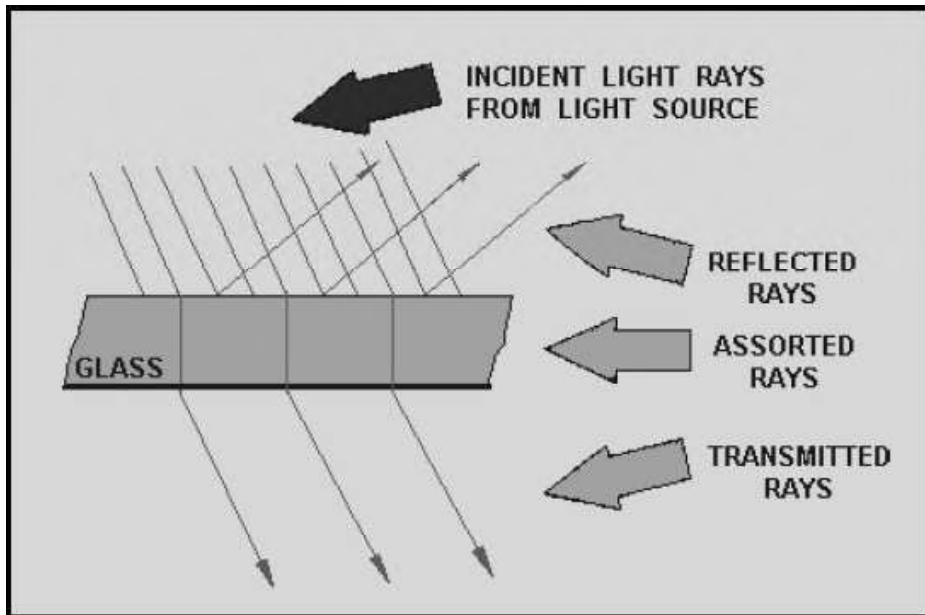

Figure 2-3. - Light waves reflected, absorbed, and transmitted

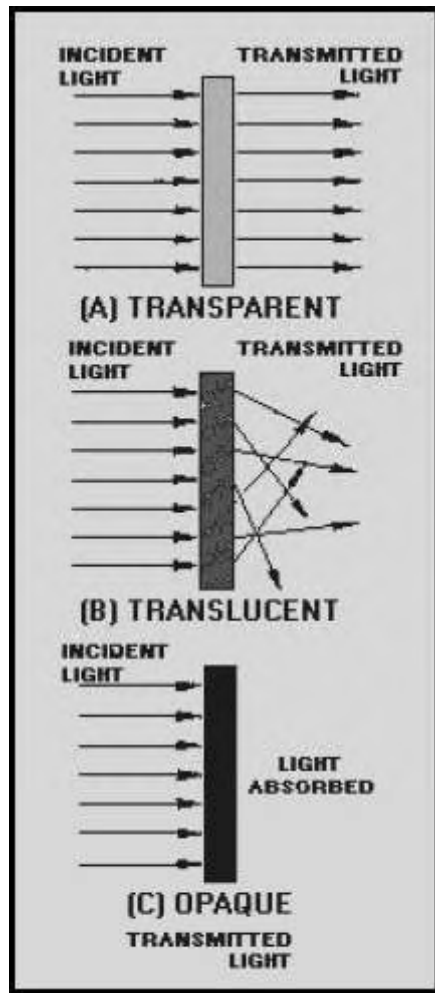

Figure 2-4. - Substances: A. Transparent; B. Translucent; and C. Opaque

All substances that are not light sources are visible only because they reflect all or some part of the light reaching them from some luminous source. Examples of luminous sources include the sun, a gas flame, and an electric light filament, because they are sources of light energy. If light is neither transmitted nor reflected, it is absorbed or taken up by the medium. When light strikes a substance, some absorption and some reflection always take place. No substance completely transmits, reflects, or absorbs all the light rays that reach its surface.

Q3. When light waves encounter any substance, what four things can happen?

Q4. A substance that transmits almost all of the light waves falling upon it is known as what type of substance?

Q5. A substance that is unable to transmit any light waves is known as what type of substance?

REFLECTION OF LIGHT

Reflected waves are simply those waves that are neither transmitted nor absorbed, but are reflected from the surface of the medium they encounter. When a wave approaches a reflecting surface, such as a mirror, the wave that strikes the surface is called the **incident wave**, and the one that bounces back is called the **reflected wave**, see figure 2-5. An imaginary line perpendicular to the point at which the incident wave strikes the reflecting surface is called the **normal**, or the perpendicular. The angle between the incident wave and the normal is called the **angle of incidence**. The angle between the reflected wave and the normal is called the **angle of reflection**.

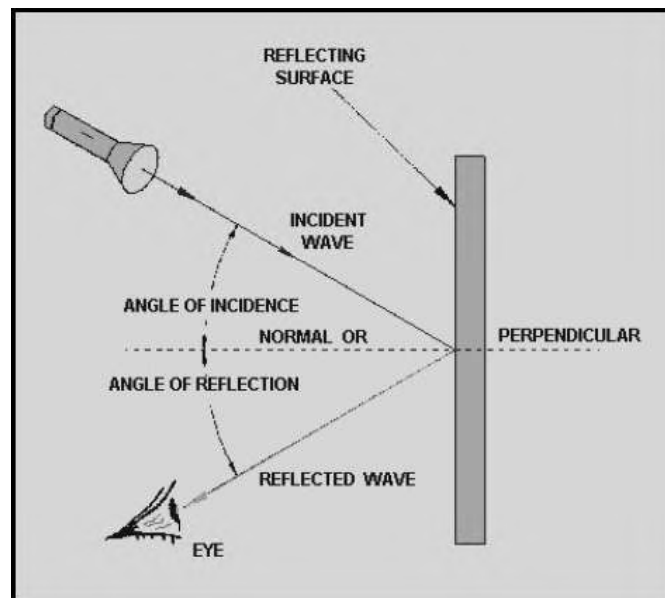

Figure 2-5. - Reflection of a wave

If the surface of the medium contacted by the incident wave is smooth and polished, each reflected wave will be reflected back at the same angle as the incident wave. The path of the wave reflected from the surface forms an angle equal to the one formed by its path in reaching the medium. This conforms to the **law of reflection** which states: The angle of incidence is equal to the angle of reflection.

The amount of incident-wave energy that is reflected from a surface depends on the nature of the surface and the angle at which the wave strikes the surface. The amount of wave energy reflected increases as the angle of incidence increases. The reflection of energy is the greatest when the wave is nearly parallel to the reflecting surface. When the incidence wave is perpendicular to the surface, more of the energy is transmitted into the

substance and reflection of energy is at its least. At any incident angle, a mirror reflects almost all of the wave energy, while a dull, black surface reflects very little.

Light waves obey the law of reflection. Light travels in a straight line through a substance of uniform density. For example, you can see the straight path of light rays admitted through a narrow slit into a darkened room. The straight path of the beam is made visible by illuminated dust particles suspended in the air. If the light is made to fall onto the surface of a mirror or other reflecting surface, however, the direction of the beam changes sharply. The light can be reflected in almost any direction, depending on the angle with which the mirror is held.

Q6. What is the law of reflection?

Q7. When a wave is reflected from a surface, energy is reflected. When is the reflection of energy the greatest?

Q8. When is the reflection energy the least?

Q9. Light waves obey what law?

REFRACTION OF LIGHT

When a light wave passes from one medium into a medium having a different velocity of propagation (the speed waves can travel through a medium), a change in the direction of the wave will occur. This change of direction as the wave enters the second medium is called refraction. As in the discussion of reflection, the wave striking the boundary (surface) is called the incident wave, and the imaginary line perpendicular to the boundary is called the normal. The angle between the incident wave and the normal is called the angle of incidence. As the wave passes through the boundary, it is bent either toward or away from the normal. The angle between the normal and the path of the wave through the second medium is the angle of refraction.

A light wave passing through a block of glass is shown in figure 2-6. The wave moves from point A to point B at a constant speed. This is the incident wave. As the wave penetrates the glass boundary at point B, the velocity of the wave is slowed down. This causes the wave to bend toward the normal. The wave then takes the path from point B to point C through the glass and becomes both the refracted wave from the top surface and the incident wave to the lower surface. As the wave passes from the glass to the air (the second boundary), it is again refracted, this time away from the normal, and takes the path from point C to point D. After passing through the last boundary, the velocity

increases to the original velocity of the wave. As illustrated, refracted waves can bend toward or away from the normal. This bending depends on the velocity of the wave through different mediums. The broken line between points B and E is the path that the wave would travel if the two mediums (air and glass) had the same density.

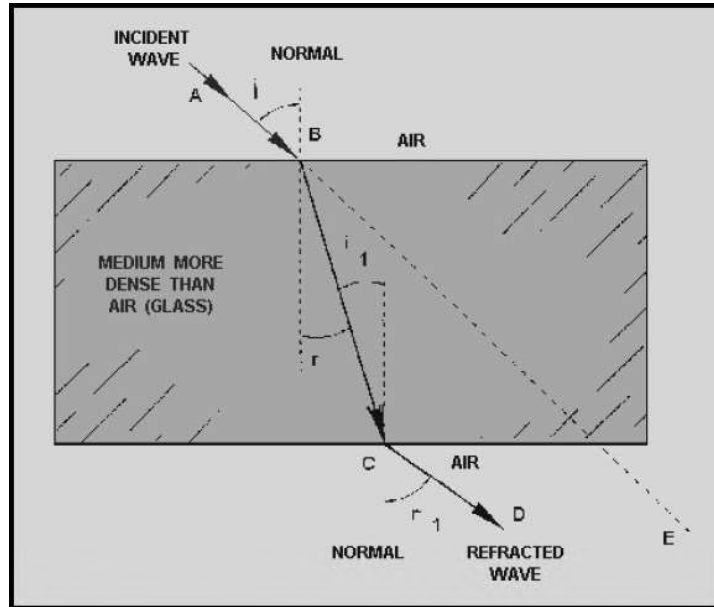

Figure 2-6. - Refraction of a wave

Another interesting condition can be shown using figure 2-6. If the wave passes from a less dense to a denser medium, it is bent toward the normal, and the angle of refraction (r) is less than the angle of incidence (i). Likewise, if the wave passes from a denser to a less dense medium, it is bent away from the normal, and the angle of refraction (r_1) is greater than the angle of incidence (i_1).

An example of refraction is the apparent bending of a spoon when it is immersed in a cup of water. The bending seems to take place at the surface of the water, or exactly at the point where there is a change of density. Obviously, the spoon does not bend from the pressure of the water. The light forming the image of the spoon is bent as it passes from the water (a medium of high density) to the air (a medium of comparatively low density).

Without refraction, light waves would pass in straight lines through transparent substances without any change of direction. Figure 2-6 shows that rays striking the glass at any angle other than perpendicular are refracted. However, perpendicular rays, which enter the glass normal to the surface, continue through the glass and into the air in a straight line—no refraction takes place.

Q10. A refracted wave occurs when a wave passes from one medium into another medium. What determines the angle of refraction?

Q11. A light wave enters a sheet of glass at a perfect right angle to the surface. Is the majority of the wave reflected, refracted, transmitted, or absorbed?

DIFFUSION OF LIGHT

When light is reflected from a mirror, the angle of reflection equals the angle of incidence. When light is reflected from a piece of plain white paper; however, the reflected beam is scattered, or diffused, as shown in figure 2-7. Because the surface of the paper is not smooth, the reflected light is broken up into many light beams that are reflected in all directions.

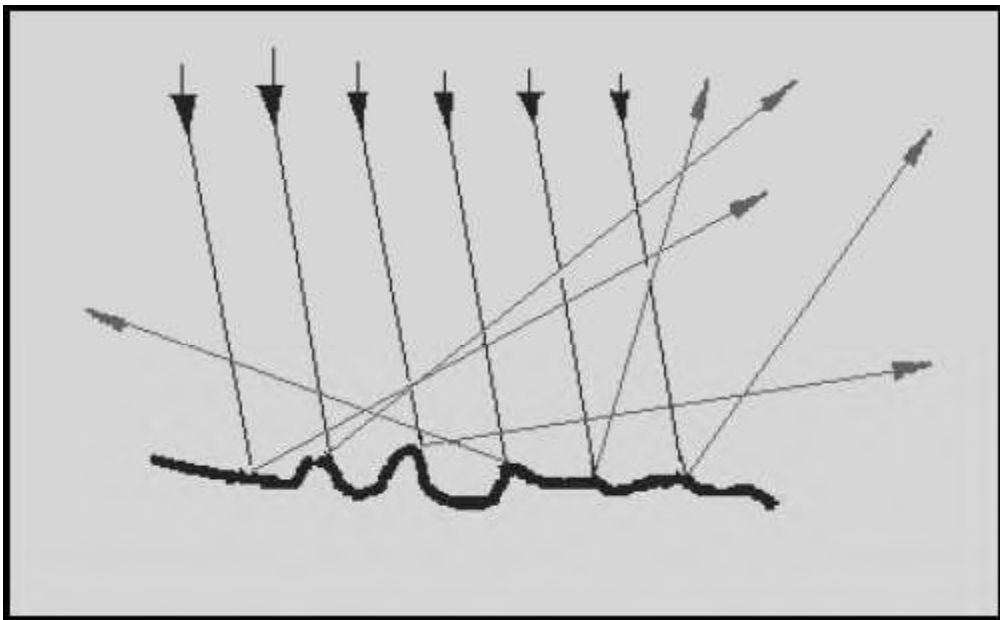

Figure 2-7. - Diffusion of light

Q12. When light strikes a piece of white paper, the light is reflected in all directions. What do we call this scattering of light?

ABSORPTION OF LIGHT

You have just seen that a light beam is reflected and diffused when it falls onto a piece of white paper. If the light beam falls onto a piece of black paper, the black paper absorbs most of the light rays and very little light is reflected from the paper. If the surface upon which the light beam falls is perfectly black, there is no reflection; that is, the light is totally absorbed. No matter what kind of surface light falls upon, some of the light is absorbed. Figure 2-7a.

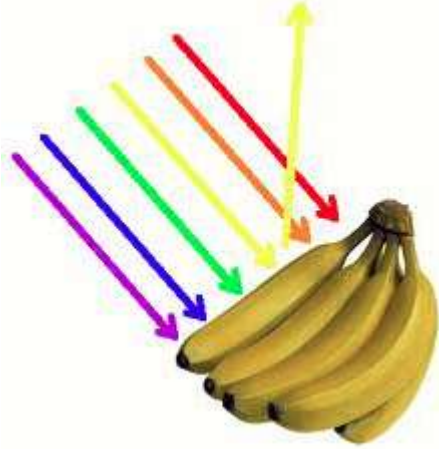

Figure 2-7a. - Absorption of light

TRANSMISSION OF LIGHT THROUGH OPTICAL FIBERS

The transmission of light along optical fibers depends not only on the nature of light, but also on the structure of the optical fiber. Two methods are used to describe how light is transmitted along the optical fiber. The first method, ray theory, uses the concepts of light reflection and refraction. The second method, mode theory, treats light as electromagnetic waves. You must first understand the basic optical properties of the materials used to make optical fibers. These properties affect how light is transmitted through the fiber.

Q13. Two methods describe how light propagates along an optical fiber. These methods define two theories of light propagation. What do we call these two theories?

BASIC OPTICAL-MATERIAL PROPERTIES

The basic optical property of a material, relevant to optical fibers, is the index of refraction. The index of refraction (n) measures the speed of light in an optical medium. The index of refraction of a material is the ratio of the speed of light in a vacuum to the speed of light in the material itself. The speed of light (c) in free space (vacuum) is 3×10^8 meters per second (m/s). The speed of light is the frequency (f) of light multiplied by the wavelength of light (λ). When light enters the fiber material (an optically dense medium), the light travels slower at a speed (v). Light will always travel slower in the fiber material than in air. The index of refraction is given by:

$$n = \frac{c}{v}$$

A light ray is reflected and refracted when it encounters the boundary between two different transparent mediums. For example, figure 2-8 shows what happens to the light ray when it encounters the interface between glass and air. The index of refraction for glass (n_1) is 1.50. The index of refraction for air (n_2) is 1.00.

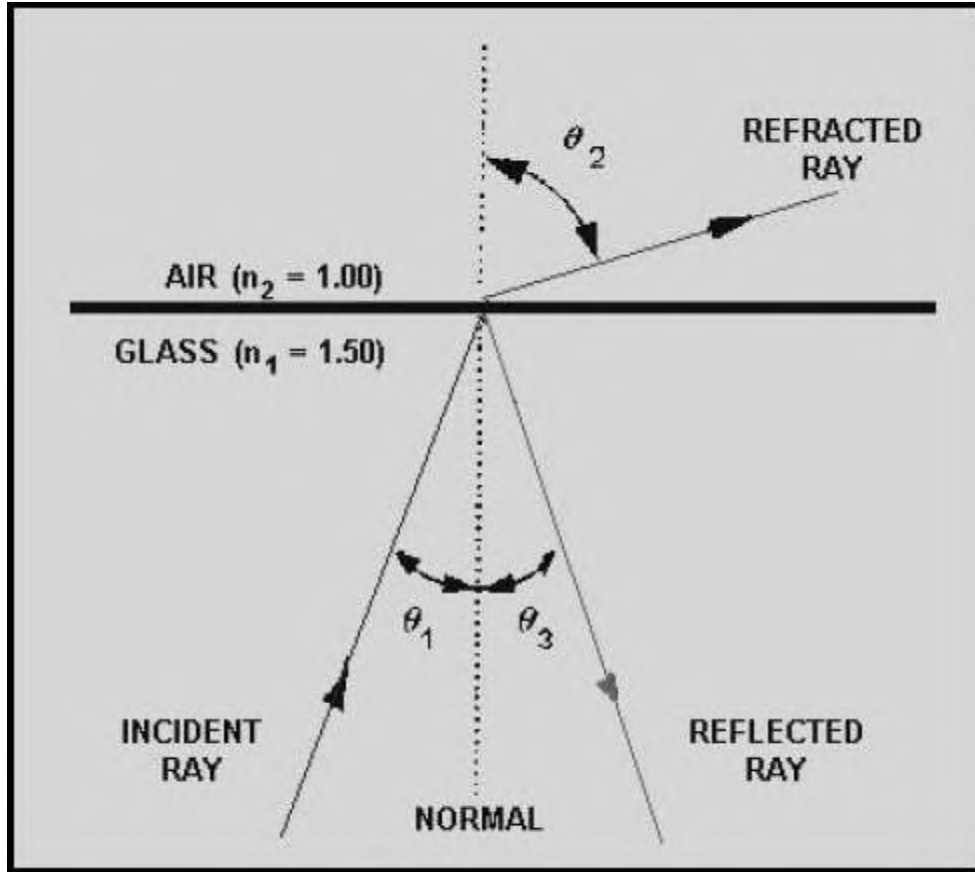

Figure 2-8. - Light reflection and refraction at a glass-air boundary

Let's assume the light ray or incident ray is traveling through the glass. When the light ray encounters the glass-air boundary, there are two results. The first result is that part of the ray is reflected back into the glass. The second result is that part of the ray is refracted (bent) as it enters the air. The bending of the light at the glass-air interface is the result of the difference between the indexes of refractions. Since n_1 is greater than n_2 , the angle of refraction (θ_2) will be greater than the angle of incidence (θ_1). Snell's law of refraction is used to describe the relationship between the incident and the refracted rays at the boundary. Snell's Law is given by:

$$n_1 \times \sin \theta_1 = n_2 \times \sin \theta_2$$

As the angle of incidence (θ_1) becomes larger, the angle of refraction (θ_2) approaches 90 degrees. At this point, no refraction is possible. The light ray is totally

reflected back into the glass medium. No light escapes into the air. This condition is called total internal reflection. The angle at which total internal reflection occurs is called the critical angle of incidence. The critical angle of incidence (θ_c) is shown in figure 2-9. At any angle of incidence (θ_1) greater than the critical angle, light is totally reflected back into the glass medium. The critical angle of incidence is determined by using Snell's Law. The critical angle is given by:

$$\sin \theta_c = \frac{n_2}{n_1}$$

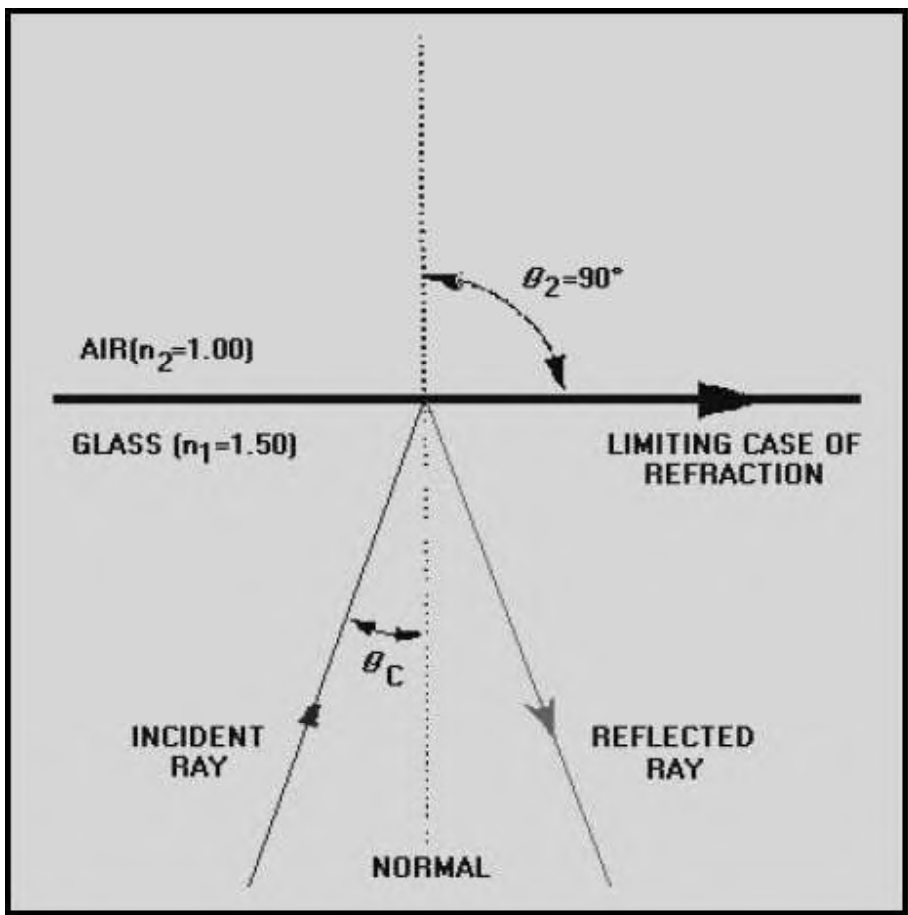

Figure 2-9. - Critical angle of incidence

The condition of total internal reflection is an ideal situation. However, in reality, there is always some light energy that penetrates the boundary. This situation is explained by the mode theory, or the electromagnetic wave theory, of light.

Q14. What is the basic optical-material property relevant to optical fiber light transmission?

Q15. The index of refraction measures the speed of light in an optical fiber. Will light travel faster in an optically dense material or in one that is less dense?

Q16. Assume light is traveling through glass, what happens when this light strikes the glass-air boundary?

Q17. What condition causes a light ray to be totally reflected back into its medium of propagation?

Q18. What name is given to the angle where total internal reflection occurs?

BASIC STRUCTURE OF AN OPTICAL FIBER

The basic structure of an optical fiber consists of three parts; the core, the cladding, and the coating or buffer. The basic structure of an optical fiber is shown in figure 2-10. The core is a cylindrical rod of dielectric material. Dielectric material conducts no electricity. Light propagates mainly along the core of the fiber. The core is generally made of glass. The core is described as having a radius of (a) and an index of refraction n_1 . The core is surrounded by a layer of material called the cladding. Even though light will propagate along the fiber core without the layer of cladding material, the cladding does perform some necessary functions.

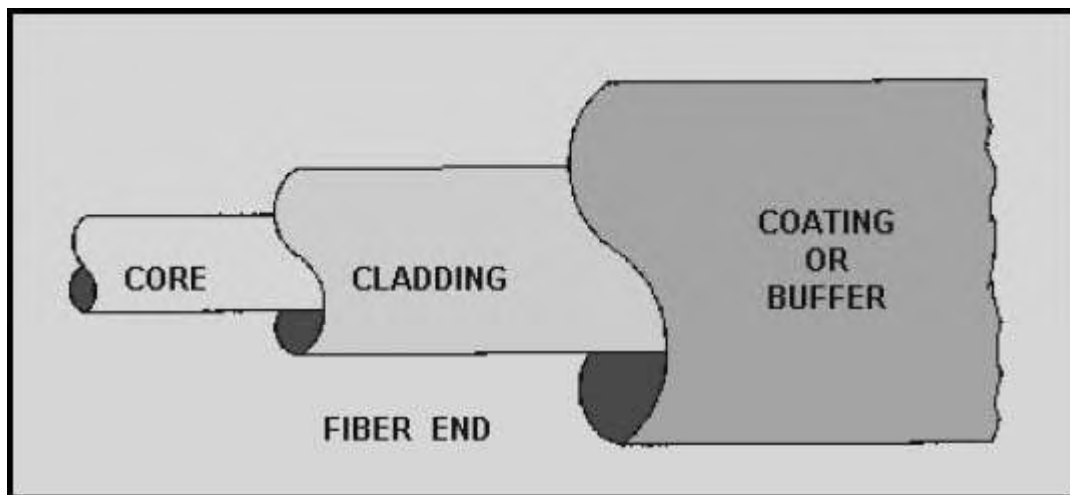

Figure 2-10. - Basic structure of an optical fiber

The cladding layer is made of a dielectric material with an index of refraction n_2 . The index of refraction of the cladding material is less than that of the core material. The

cladding is generally made of glass or plastic. The cladding performs the following functions:

- Reduces loss of light from the core into the surrounding air
- Reduces scattering loss at the surface of the core
- Protects the fiber from absorbing surface contaminants
- Adds mechanical strength

For extra protection, the cladding is enclosed in an additional layer called the coating or buffer. The coating or buffer is a layer of material used to protect an optical fiber from physical damage. The material used for a buffer is a type of plastic. The buffer is elastic in nature and prevents abrasions. The buffer also prevents the optical fiber from scattering losses caused by microbends. Microbends occur when an optical fiber is placed on a rough and distorted surface. Microbends are discussed later in this chapter.

Q19. List the three parts of an optical fiber.

Q20. Which fiber material, core or cladding, has a higher index of refraction?

PROPAGATION OF LIGHT ALONG A FIBER

The concept of light propagation, the transmission of light along an optical fiber, can be described by two theories. According to the first theory, light is described as a simple ray. This theory is the ray theory, or geometrical optics, approach. The advantage of the ray approach is that you get a clearer picture of the propagation of light along a fiber. The ray theory is used to approximate the light acceptance and guiding properties of optical fibers. According to the second theory, light is described as an electromagnetic wave. This theory is the mode theory, or wave representation, approach. The mode theory describes the behavior of light within an optical fiber. The mode theory is useful in describing the optical fiber properties of absorption, attenuation, and dispersion. These fiber properties are discussed later in this chapter.

Q21. Light transmission along an optical fiber is described by two theories. Which theory is used to approximate the light acceptance and guiding properties of an optical fiber?

Ray Theory

Two types of rays can propagate along an optical fiber. The first type is called meridional rays. Meridional rays are rays that pass through the axis of the optical fiber. Meridional rays are used to illustrate the basic transmission properties of optical fibers.

The second type is called skew rays. Skew rays are rays that travel through an optical fiber without passing through its axis.

MERIDIONAL RAYS.—Meridional rays can be classified as bound or unbound rays. Bound rays remain in the core and propagate along the axis of the fiber. Bound rays propagate through the fiber by total internal reflection. Unbound rays are refracted out of the fiber core. Figure 2-11 shows a possible path taken by bound and unbound rays in a step-index fiber. The core of the step-index fiber has an index of refraction n_1 . The cladding of a step-index has an index of refraction n_2 that is lower than n_1 . Figure 2-11 assumes the core-cladding interface is perfect. However, imperfections at the core-cladding interface will cause part of the bound rays to be refracted out of the core into the cladding. The light rays refracted into the cladding will eventually escape from the fiber. In general, meridional rays follow the laws of reflection and refraction.

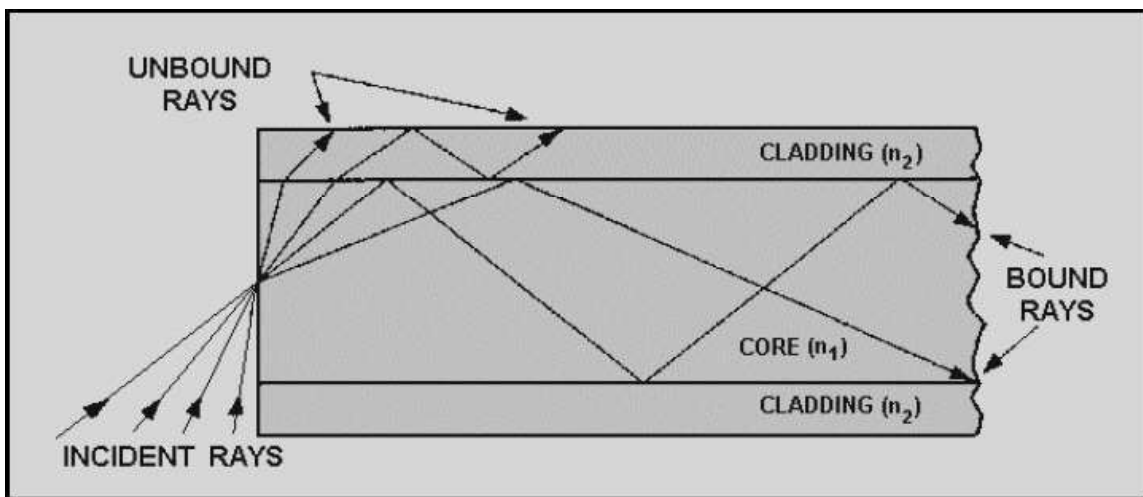

Figure 2-11. - Bound and unbound rays in a step-index fiber

It is known that bound rays propagate in fibers due to total internal reflection, but how do these light rays enter the fiber? Rays that enter the fiber must intersect the core-cladding interface at an angle greater than the critical angle (θ_c). Only those rays that enter the fiber and strike the interface at these angles will propagate along the fiber.

How a light ray is launched into a fiber is shown in figure 2-12. The incident ray I_1 enters the fiber at the angle θ_a . I_1 is refracted upon entering the fiber and is transmitted to the core-cladding interface. The ray then strikes the core-cladding interface at the critical angle (θ_c). I_1 is totally reflected back into the core and continues to propagate along the fiber. The incident ray I_2 enters the fiber at an angle greater than θ_a . Again, I_2 is refracted upon entering the fiber and is transmitted to the core-cladding interface. I_2 strikes the core-cladding interface at an angle less than the critical angle (θ_c). I_2 is refracted into the cladding and is eventually lost. The light ray incident on the fiber core must be within the acceptance cone defined by the angle θ_a shown in figure 2-13. Angle θ_a is defined as the acceptance angle. The acceptance angle (θ_a) is the maximum angle to the

axis of the fiber that light entering the fiber is propagated. The value of the angle of acceptance (θ_a) depends on fiber properties and transmission conditions.

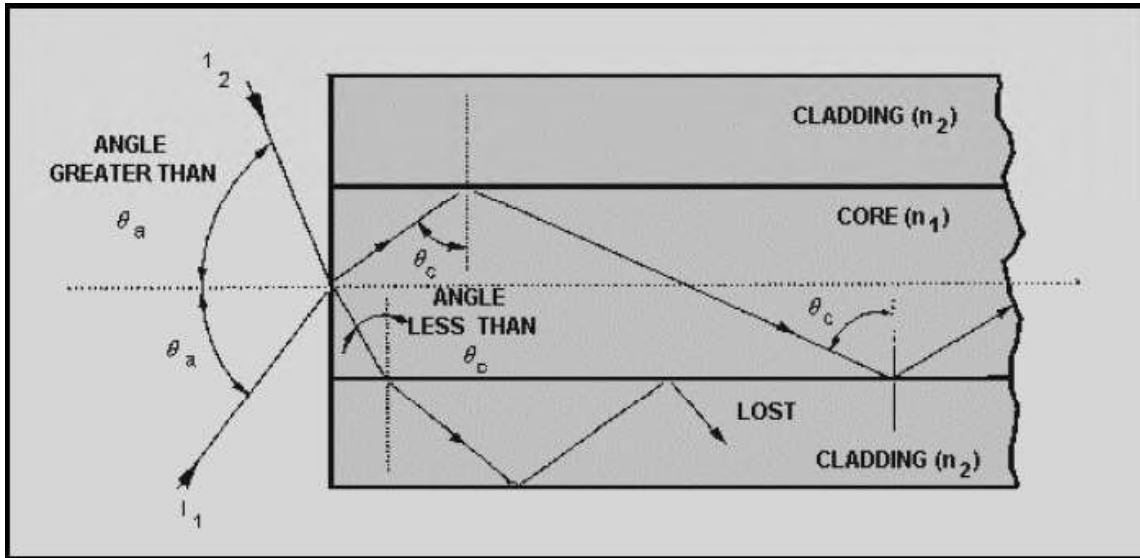

Figure 2-12. - How a light ray enters an optical fiber

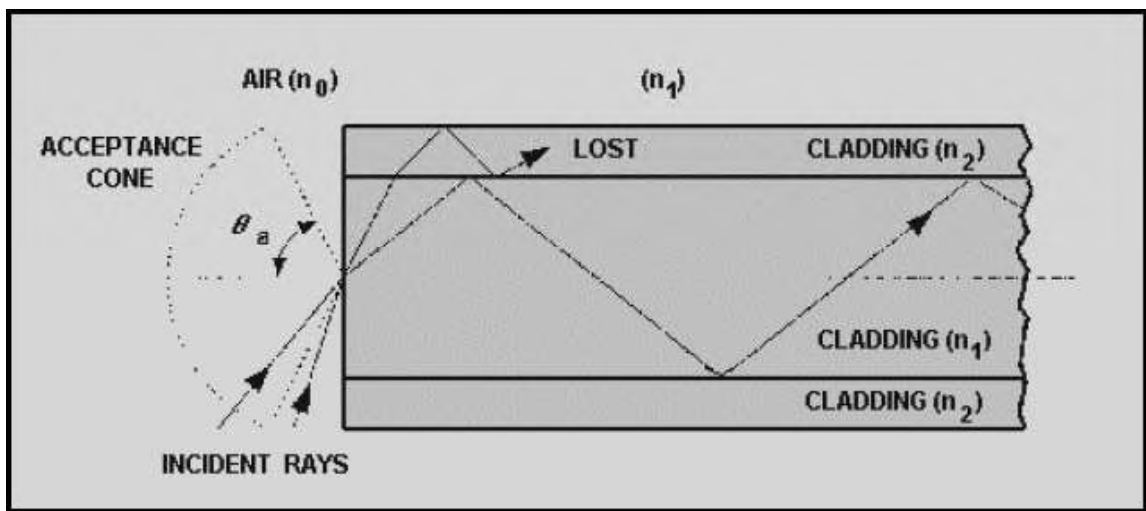

Figure 2-12 Fiber acceptance angle

The acceptance angle is related to the refractive indices of the core, cladding, and medium surrounding the fiber. This relationship is called the numerical aperture of the fiber. The numerical aperture (NA) is a measurement of the ability of an optical fiber to capture light. The NA is also used to define the acceptance cone of an optical fiber.

Figure 2-13 illustrates the relationship between the acceptance angle and the refractive indices. The index of refraction of the fiber core is n_1 . The index of refraction of the fiber cladding is n_2 . The index of refraction of the surrounding medium is n_0 . By using Snell's law and basic trigonometric relationships, the NA of the fiber is given by:

$$NA = n_0 \times \sin \Theta_a = (n_1^2 - n_2^2)^{\frac{1}{2}}$$

Since the medium next to the fiber at the launching point is normally air, n_0 is equal to 1.00. The NA is then simply equal to $\sin \Theta_a$. The NA is a convenient way to measure the light-gathering ability of an optical fiber. It is used to measure source-to-fiber power-coupling efficiencies. A high NA indicates a high source-to-fiber coupling efficiency. Source-to-fiber coupling efficiency is described in chapter 6. Typical values of NA range from 0.20 to 0.29 for glass fibers. Plastic fibers generally have a higher NA. An NA for plastic fibers can be higher than 0.50.

In addition, the NA is commonly used to specify multimode fibers. However, for small core diameters, such as in single mode fibers, the ray theory breaks down. Ray theory describes only the direction a plane wave takes in a fiber. Ray theory eliminates any properties of the plane wave that interfere with the transmission of light along a fiber. In reality, plane waves interfere with each other. Therefore, only certain types of rays are able to propagate in an optical fiber. Optical fibers can support only a specific number of guided modes. In small core fibers, the number of modes supported is one or only a few modes. Mode theory is used to describe the types of plane waves able to propagate along an optical fiber.

SKEW RAYS.—A possible path of propagation of skew rays is shown in figure 2-14. Figure 2-14, view A, provides an angled view and view B provides a front view. Skew rays propagate without passing through the center axis of the fiber. The acceptance angle for skew rays is larger than the acceptance angle of meridional rays. This condition explains why skew rays outnumber meridional rays. Skew rays are often used in the calculation of light acceptance in an optical fiber. The addition of skew rays increases the amount of light capacity of a fiber. In large NA fibers, the increase may be significant.

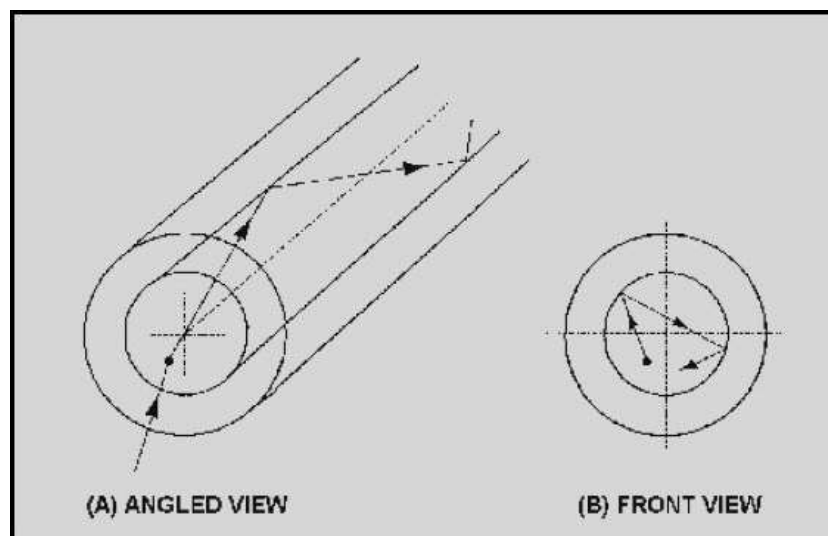

Figure 2-14. - Skew ray propagation: A. Angled view; B. Front view

The addition of skew rays also increases the amount of loss in a fiber. Skew rays tend to propagate near the edge of the fiber core. A large portion of the number of skew rays that are trapped in the fiber core are considered to be leaky rays. Leaky rays are predicted to be totally reflected at the core-cladding boundary. However, these rays are partially refracted because of the curved nature of the fiber boundary. Mode theory is also used to describe this type of leaky ray loss.

Q22. Meridional rays are classified as either bound or unbound rays. Bound rays propagate through the fiber according to what property?

Q23. A light ray incident on the optical fiber core is propagated along the fiber. Is the angle of incidence of the light ray entering the fiber larger or smaller than the acceptance angle (θ_a)

Q24. What fiber property does numerical aperture (NA) measure?

Q25. Skew rays and meridional rays define different acceptance angles. Which acceptance angle is larger, the skew ray angle or the meridional ray angle?

Mode Theory

The mode theory, along with the ray theory, is used to describe the propagation of light along an optical fiber. The mode theory is used to describe the properties of light that ray theory is unable to explain. The mode theory uses electromagnetic wave behavior to describe the propagation of light along a fiber. A set of guided electromagnetic waves is called the modes of the fiber.

Q26. The mode theory uses electromagnetic wave behavior to describe the propagation of the light along the fiber. What is a set of guided electromagnetic waves called?

PLANE WAVES.—The mode theory suggests that a light wave can be represented as a plane wave. A plane wave is described by its direction, amplitude, and wavelength of propagation. A plane wave is a wave whose surfaces of constant phase are infinite parallel planes normal to the direction of propagation. The planes having the same phase are called the wave fronts. The wavelength (λ) of the plane wave is given by:

$$\text{wavelength } (\lambda) = \frac{c}{fn}$$

where c is the speed of light in a vacuum, f is the frequency of the light, and n is the index of refraction of the plane-wave medium.

Figure 2-15 shows the direction and wave fronts of plane-wave propagation. Plane waves, or wave fronts, propagate along the fiber similar to light rays. However, not all wave fronts incident on the fiber at angles less than or equal to the critical angle of light acceptance propagate along the fiber. Wave fronts may undergo a change in phase that prevents the successful transfer of light along the fiber.

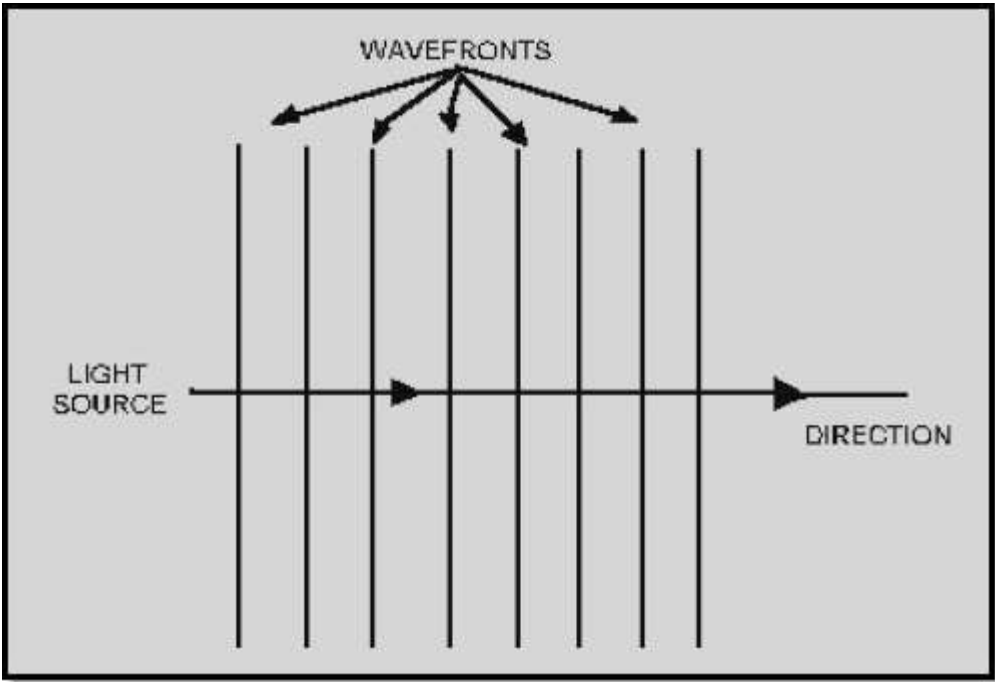

Figure 2-15. - Plane-wave propagation

Wave fronts are required to remain in phase for light to be transmitted along the fiber. Consider the wave front incident on the core of an optical fiber as shown in figure 2-15. Only those wave fronts incident on the fiber at angles less than or equal to the critical angle may propagate along the fiber. The wave front undergoes a gradual phase change as it travels down the fiber. Phase changes also occur when the wave front is reflected. The wave front must remain in phase after the wave front transverses the fiber twice and is reflected twice. The distance transversed is shown between point A and point B on figure 2-16. The reflected waves at point A and point B are in phase if the total amount of phase collected is an integer multiple of 2π radian. If propagating wave fronts are not in phase, they eventually disappear. Wave fronts disappear because of destructive

interference. The wave fronts that are in phase interfere with the wave fronts that are out of phase. This interference is the reason why only a finite number of modes can propagate along the fiber.

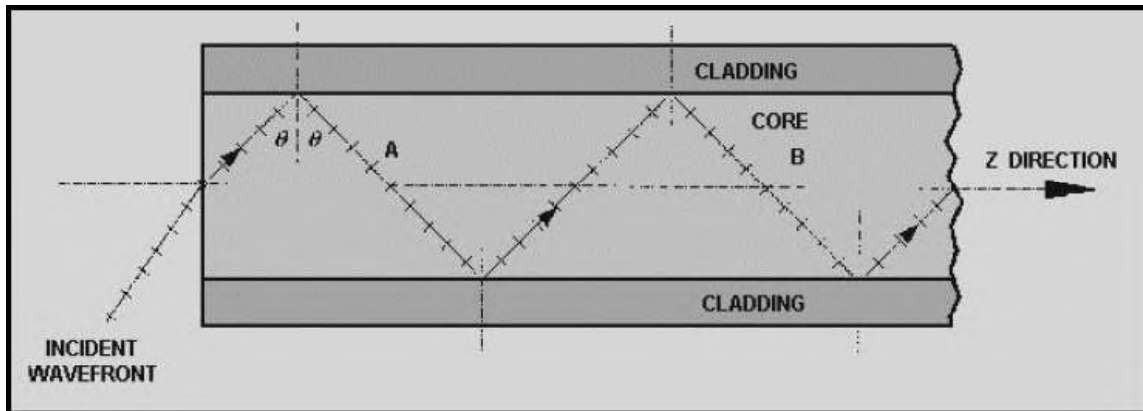

Figure 2-16. - Wave front propagation along an optical fiber

The plane waves repeat as they travel along the fiber axis. The direction the plane wave's travel is assumed to be the z direction as shown in figure 2-16. The plane waves repeat at a distance equal to $\lambda/\sin \theta$. Plane waves also repeat at a periodic frequency $\beta = 2\pi \sin \theta/\lambda$. The quantity β is defined as the propagation constant along the fiber axis. As the wavelength (λ) changes, the value of the propagation constant must also change. For a given mode, a change in wavelength can prevent the mode from propagating along the fiber. The mode is no longer bound to the fiber. The mode is said to be cut off. Modes that are bound at one wavelength may not exist at longer wavelengths. The wavelength at which a mode ceases to be bound is called the cutoff wavelength for that mode. However, an optical fiber is always able to propagate at least one mode. This mode is referred to as the fundamental mode of the fiber. The fundamental mode can never be cut off. The wavelength that prevents the next higher mode from propagating is called the cutoff wavelength of the fiber. An optical fiber that operates above the cutoff wavelength (at a longer wavelength) is called a single mode fiber. An optical fiber that operates below the cutoff wavelength is called a multimode fiber. Single mode and multimode optical fibers are discussed later in this chapter.

In a fiber, the propagation constant of a plane wave is a function of the wave's wavelength and mode. The change in the propagation constant for different waves is called dispersion. The change in the propagation constant for different wavelengths is called chromatic dispersion. The change in propagation constant for different modes is called modal dispersion. These dispersions cause the light pulse to spread as it goes down the fiber, see figure 2-17. Some dispersion occurs in all types of fibers. Dispersion is discussed later in this chapter.

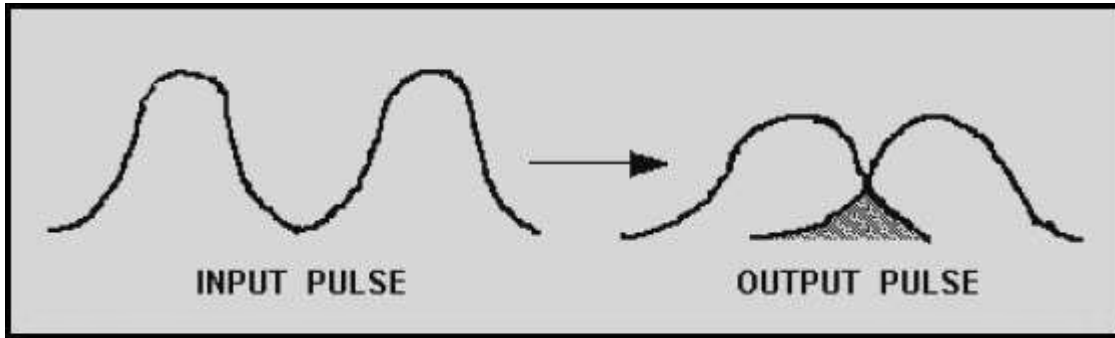

Figure 2-17. - The spreading of a light pulse

MODES.—A set of guided electromagnetic waves is called the modes of an optical fiber. Maxwell's equations describe electromagnetic waves or modes as having two components. The two components are the electric field, $E(x, y, z)$, and the magnetic field, $H(x, y, z)$. The electric field, E , and the magnetic field, H , are at right angles to each other. Modes traveling in an optical fiber are said to be transverse. The transverse modes, shown in figure 2-18, propagate along the axis of the fiber. The mode field patterns shown in figure 2-18 are said to be transverse electric (TE). In TE modes, the electric field is perpendicular to the direction of propagation. The magnetic field is in the direction of propagation. Another type of transverse mode is the transverse magnetic (TM) mode. TM modes are opposite to TE modes. In TM modes, the magnetic field is perpendicular to the direction of propagation. The electric field is in the direction of propagation. Figure 2-18 shows only TE modes.

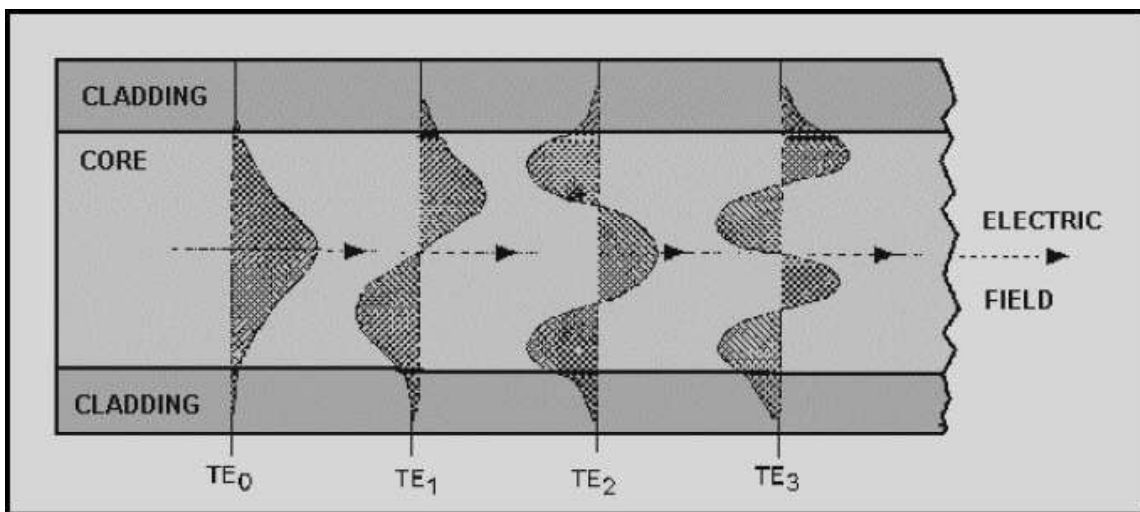

Figure 2-18. - Transverse electric (TE) mode field patterns

The TE mode field patterns shown in figure 2-18 indicate the order of each mode. The order of each mode is indicated by the number of field maxima within the core of the fiber. For example, TE_0 has one field maxima. The electric field is a maximum at the center of the waveguide and decays toward the core cladding boundary. TE_0 is considered the fundamental mode or the lowest order standing wave. As the number of field maxima

increases, the order of the mode is higher. Generally, modes with more than a few (5-10) field maxima are referred to as high-order modes.

The order of the mode is also determined by the angle the wave front makes with the axis of the fiber. Figure 2-19 illustrates light rays as they travel down the fiber. These light rays indicate the direction of the wave fronts. High-order modes cross the axis of the fiber at steeper angles. Low-order and high-order modes are shown in figure 2-19.

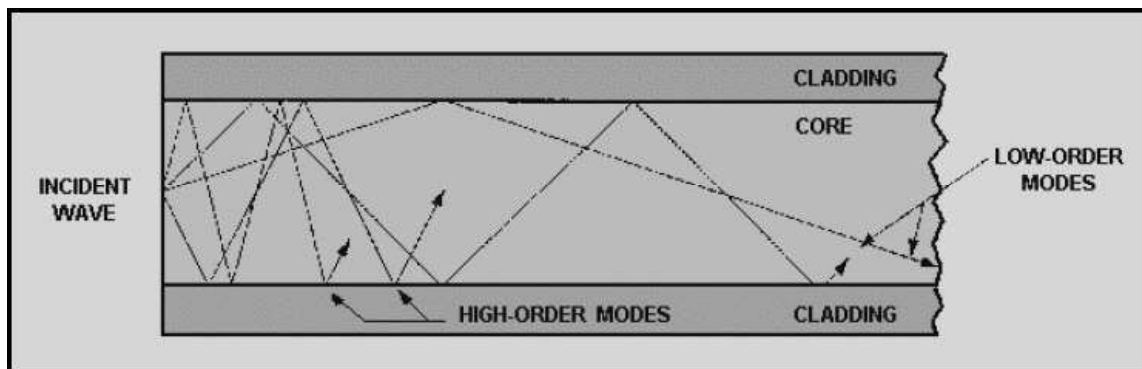

Figure 2-19. - Low-order and high-order modes

Before we progress, let us refer back to figure 2-18. Notice that the modes are not confined to the core of the fiber. The modes extend partially into the cladding material. Low-order modes penetrate the cladding only slightly. In low-order modes, the electric and magnetic fields are concentrated near the center of the fiber. Low-order modes take parallel or modestly transverse paths. However, high-order modes penetrate further into the cladding material and take considerably more transverse paths. In high-order modes, the electrical and magnetic fields are distributed more toward the outer edges of the fiber.

This penetration of low-order and high-order modes into the cladding region indicates that some portion is refracted out of the core. The refracted modes may become trapped in the cladding due to the dimension of the cladding region. The modes trapped in the cladding region are called cladding modes. As the core and the cladding modes travel along the fiber, mode coupling occurs. Mode coupling is the exchange of power between two modes. Mode coupling to the cladding results in the loss of power from the core modes.

In addition to bound and refracted modes, there are leaky modes. Leaky modes are similar to leaky rays. Leaky modes lose power as they propagate along the fiber. For a mode to remain within the core, the mode must meet certain boundary conditions. A mode remains bound if the propagation constant β meets the following boundary condition:

$$\frac{2\pi n_2}{\lambda} < \beta < \frac{2\pi n_1}{\lambda}$$

where n_1 and n_2 are the index of refraction for the core and the cladding, respectively. When the propagation constant becomes smaller than $2\pi n_2/\lambda$, power leaks out of the core and into the cladding. Generally, modes leaked into the cladding are lost in a few centimeters. However, leaky modes can carry a large amount of power in short fibers.

NORMALIZED FREQUENCY.—Electromagnetic waves bound to an optical fiber are described by the fiber's normalized frequency. The normalized frequency determines how many modes a fiber can support. Normalized frequency is a dimensionless quantity. Normalized frequency is also related to the fiber's cutoff wavelength. Normalized frequency (V) is defined as:

$$V = \frac{2\pi a}{\lambda} (n_1^2 - n_2^2)^{\frac{1}{2}}$$

where n_1 is the core index of refraction, n_2 is the cladding index of refraction, a is the core diameter, and λ is the wavelength of light in air.

The number of modes that can exist in a fiber is a function of V . As the value of V increases, the number of modes supported by the fiber increases. Optical fibers, single mode and multimode, can support a different number of modes. The number of modes supported by single mode and multimode fiber types is discussed later in this chapter.

Q27. A light wave can be represented as a plane wave. What three properties of light propagation describe a plane wave?

Q28. A wave front undergoes a phase change as it travels along the fiber. If the wave front transverses the fiber twice and is reflected twice and the total phase change is equal to $1/2\pi$, will the wave front disappear? If yes, why?

Q29. Modes that are bound at one wavelength may not exist at longer wavelengths. What is the wavelength at which a mode ceases to be bound called?

Q30. What type of optical fiber operates below the cutoff wavelength?

Q31. Low-order and high-order modes propagate along an optical fiber. How are modes determined to be low-order or high-order modes?

Q32. As the core and cladding modes travel along the fiber, mode coupling occurs. What is mode coupling?

Q33. The fiber's normalized frequency (V) determines how many modes a fiber can support. As the value of V increases, will the number of modes supported by the fiber increase or decrease?

OPTICAL FIBER TYPES

Optical fibers are characterized by their structure and by their properties of transmission. Basically, optical fibers are classified into two types. The first type is single mode fibers. The second type is multimode fibers. As each name implies, optical fibers are classified by the number of modes that propagate along the fiber. As previously explained, the structure of the fiber can permit or restrict modes from propagating in a fiber. The basic structural difference is the core size. Single mode fibers are manufactured with the same materials as multimode fibers. Single mode fibers are also manufactured by following the same fabrication process as multimode fibers.

Single Mode Fibers

The core size of single mode fibers is small. The core size (diameter) is typically around 8 to 10 micrometers (μm). A fiber core of this size allows only the fundamental or lowest order mode to propagate around a 1300 nanometer (nm) wavelength. Single mode fibers propagate only one mode, because the core size approaches the operational wavelength (λ). This is achieved by using a LASER as a light source. The value of the normalized frequency parameter (V) relates core size with mode propagation. In single mode fibers, V is less than or equal to 2.405. When $V > 2.405$, single mode fibers propagate the fundamental mode down the fiber core, while high-order modes are lost in the cladding. For low V values (< 1.0), most of the power is propagated in the cladding material. Power transmitted by the cladding is easily lost at fiber bends. The value of V should remain near the 2.405 level.

Single mode fibers have a lower signal loss and a higher information capacity (bandwidth) than multimode fibers. Single mode fibers are capable of transferring higher amounts of data due to low fiber dispersion. Basically, dispersion is the spreading of light as light propagates along a fiber. Dispersion mechanisms in single mode fibers are discussed in more detail later in this chapter. Signal loss depends on the operational wavelength (λ). In single mode fibers, the wavelength can increase or decrease the losses

caused by fiber bending. Single mode fibers operating at wavelengths larger than the cutoff wavelength lose more power at fiber bends. They lose power because light radiates into the cladding, which is lost at fiber bends. In general, single mode fibers are considered to be low-loss fibers, which increase system bandwidth and length.

Q34. The value of the normalized frequency parameter (V) relates the core size with mode propagation. When single mode fibers propagate only the fundamental mode, what is the value of V ?

Multimode Fibers

As their name implies, multimode fibers propagate more than one mode. Multimode fibers can propagate over 100 modes. The number of modes propagated depends on the core size and numerical aperture (NA). As the core size and NA increase, the number of modes increases. Typical values of fiber core size and NA are 50 to 100 μm and 0.20 to 0.29, respectively.

A large core size and a higher NA have several advantages. Light is launched into a multimode fiber with more ease. The higher NA and the larger core size make it easier to make fiber connections. During fiber splicing, core-to-core alignment becomes less critical. Another advantage is that multimode fibers permit the use of light-emitting diodes (LEDs). Single mode fibers typically must use LASER diodes. LEDs are cheaper, less complex, and last longer. LEDs are preferred for most applications.

Multi-mode fibers are described by their core and cladding diameters. Thus, 62.5/125 μm multi-mode fiber has a core size of 62.5 micrometers (μm) and a cladding diameter of 125 μm . The transition between the core and cladding can be sharp, which is called a step-index profile, or a gradual transition, which is called a graded-index profile. The two types have different dispersion characteristics and thus different effective propagation distance. Multi-mode fibers may be constructed with either graded or step-index profile.

In addition, multi-mode fibers are described using a system of classification determined by the ISO 11801 standard — OM1, OM2, OM3 — which is based on the modal bandwidth of the multi-mode fiber & OM4. OM4 cable will support 125m links at 40 and 100 Gbit/s. The letters "OM" stand for *optical multi-mode*.

For many years 62.5/125 μm (OM1) and conventional 50/125 μm multi-mode fiber (OM2) were widely deployed in premises applications. These fibers easily support applications ranging from Ethernet (10 Mbit/s) to Gigabit Ethernet (1 Gbit/s) and, because of their relatively large core size, were ideal for use with LED transmitters. Newer deployments often use laser-optimized 50/125 μm multi-mode fiber (OM3). Fibers that meet this designation provide sufficient bandwidth to support 10 Gigabit Ethernet up to 300 meters. Optical fiber manufacturers have greatly refined their manufacturing process since that standard was issued and cables can be made that

support 10 GbE up to 550 meters (OM4). Laser Optimized Multi-mode Fiber (LOMMF) is designed for use with 850 nm Vertical-Cavity Surface Emitting Laser (VCSEL).

The migration to LOMMF/OM3 has occurred as users upgrade to higher speed networks. LEDs have a maximum modulation rate of 622 Mbit/s because they cannot be turned on/off fast enough to support higher bandwidth applications. VCSELs are capable of modulation over 10 Gbit/s and are used in many high speed networks.

Cables can sometimes be distinguished by jacket color: for 62.5/125 μm (OM1) and 50/125 μm (OM2), orange jackets are recommended, while Aqua is recommended for 50/125 μm "Laser Optimized" OM3 and OM4 fiber.

VCSEL power profiles, along with variations in fiber uniformity, can cause modal dispersion which is measured by differential modal delay (DMD). Modal dispersion is an effect caused by the different speeds of the individual modes in a light pulse. The net effect causes the light pulse to separate or spread over distance, making it difficult for receivers to identify the individual 1's and 0's (this is called inter-symbol interference). The greater the length, the greater the modal dispersion. To combat modal dispersion, LOMMF is manufactured in a way that eliminates variations in the fiber which could affect the speed that a light pulse can travel. The refractive index profile is enhanced for VCSEL transmission and to prevent pulse spreading. As a result the fibers maintain signal integrity over longer distances, thereby maximizing the bandwidth.

2 Transmission Standards	3 100 Mb Ethernet	4 1 Gb (1000 Mb) Ethernet	10 Gb Ethernet	40 Gb Ethernet	100 Gb Ethernet
OM1 (62.5/125)	up to 2000 meters (FX)	275 meters (SX)	33 meters (SR)	Not supported	Not supported
OM2 (50/125)	up to 2000 meters (FX)	550 meters (SX)	82 meters (SR)	Not supported	Not supported
OM3 (50/125)	up to 2000 meters (FX)	800 meters (SX)	300 meters (SR)	100 meters	100 meters
OM4 (50/125)	up to 2000 meters (FX)	880 meters (SX)	300 meters (SR)	125 meters	125 meters

Q35. The number of modes propagated in a multimode fiber depends on core size and numerical aperture (NA). If the core size and the NA decrease, will the number of modes propagated increase or decrease?

Q36. What are the different classifications of multimode fiber?

Plastic Optical Fiber (POF)

POF is an optical fiber which is made out of plastic, traditionally from PMMA (poly methyl meth acrylate), a transparent shatter resistant alternative to silica glass (sometimes referred to as acrylic glass). PMMA is an economical alternative to silica

glass when extreme strength is not necessary. It is often preferred because of its ease in handling and processing and low cost. The core size of POF is in some cases 100 times larger than glass fiber. In larger diameter fiber, up to 96% of the cross section is the core that allows the transmission of light. POF is often called the “consumer” optical fiber because the fiber and the associated components are all relatively inexpensive. Common applications include sensing or where low speed and short distances (less than 100 meters) make POF desired. Digital home appliances, home networks, industrial networks, and automotive networks are also common applications.

Hard Clad Silica (HCS)

HCS is a fiber with a core of silica glass (200 μm) and an optical cladding made of special plastic (230 μm). HCS fibers are limited to distances up to 2 kilometers and are used in local networks in buildings or small industries. Comparing both bandwidth and distances, HCS fibers rank between POF and multimode & single mode fibers.

Plastic Clad Silica (PCS)

PCS fiber is an optical fiber that has a silica based core and a plastic cladding. PCS fibers in general have significantly lower performance characteristics, higher transmission losses, and lower bandwidths than all glass fibers. PCS is commonly used in industrial, medical, or component sensing applications where cores that are larger than standard fibers are more advantageous.

PROPERTIES OF OPTICAL FIBER TRANSMISSION

The principles behind the transfer of light along an optical fiber were discussed earlier in this chapter. You learned that propagation of light depended on the nature of light and the structure of the optical fiber. However, our discussion did not describe how optical fibers affect system performance. In this case, system performance deals with signal loss and bandwidth.

Signal loss and system bandwidth describe the amount of data transmitted over a specified length of fiber. Many optical fiber properties increase signal loss and reduce system bandwidth. The most important properties that affect system performance are fiber attenuation and dispersion.

Attenuation reduces the amount of optical power transmitted by the fiber. Attenuation controls the distance an optical signal (pulse) can travel as shown in figure 2-20. Once the power of an optical pulse is reduced to a point where the receiver is unable to detect the pulse, an error occurs. Attenuation is mainly a result of **light absorption**, **scattering**, and **bending losses**. Dispersion spreads the optical pulse as it travels along the fiber. This spreading of the signal pulse reduces the system bandwidth or the information-carrying capacity of the fiber. Dispersion limits how fast information is transferred as shown in figure 2-20. An error occurs when the receiver is unable to distinguish between input pulses caused by the spreading of each pulse. The effects of

attenuation and dispersion increase as the pulse travels the length of the fiber as shown in figure 2-21.

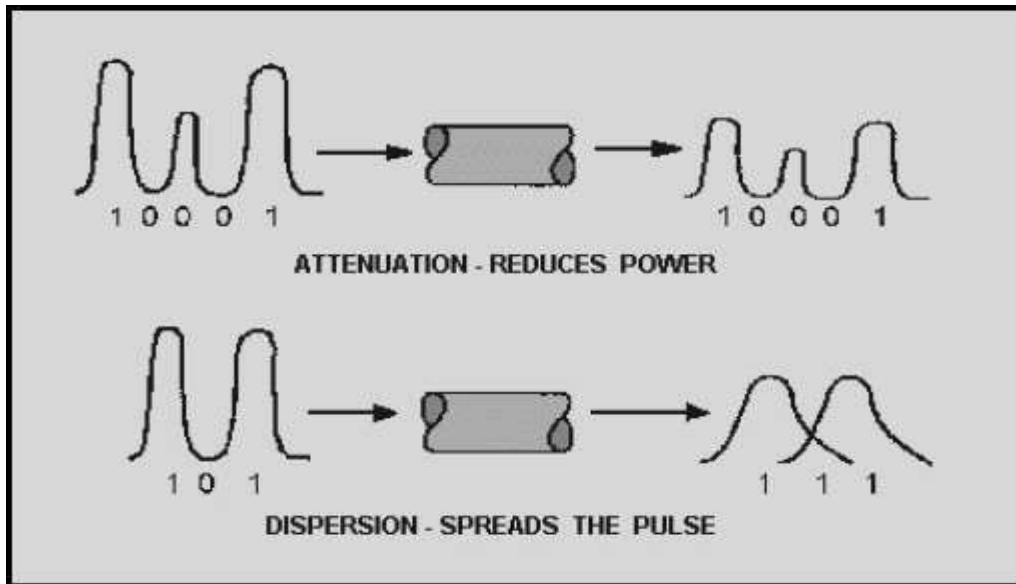

Figure 2-20. - Fiber transmission properties

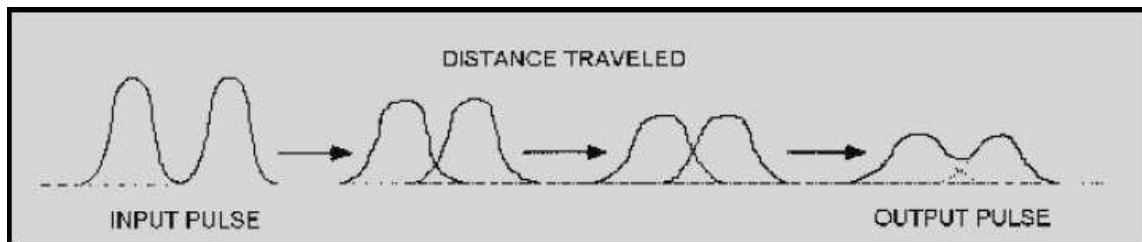

Figure 2-21. -Pulse spreading and power loss along an optical fiber

In addition to fiber attenuation and dispersion, other optical fiber properties affect system performance. Fiber properties, such as modal noise, pulse broadening, and polarization, can reduce system performance. Modal noise, pulse broadening, and polarization are too complex to discuss as introductory level material. However, you should be aware that attenuation and dispersion are not the only fiber properties that affect performance.

Q37. Attenuation is mainly a result of what three properties?

Attenuation

Attenuation in an optical fiber is caused by absorption, scattering, and bending losses. Attenuation is the loss of optical power as light travels along the fiber. Signal attenuation is defined as the ratio of optical input power (P_i) to the optical output power

(P_o). Optical input power is the power injected into the fiber from an optical source. Optical output power is the power received at the fiber end or optical detector. The following equation defines signal attenuation as a unit of length:

$$\text{attenuation} = \left(\frac{10}{L} \right) \log_{10} \left(\frac{P_i}{P_o} \right)$$

Signal attenuation is a log relationship. Length (L) is expressed in kilometers. Therefore, the unit of attenuation is decibels/kilometer (dB/km).

As previously stated, attenuation is caused by absorption, scattering, and bending losses. Each mechanism of loss is influenced by fiber-material properties and fiber structure. However, loss is also present at fiber connections. Fiber connector, splice, and coupler losses are discussed in chapter 4. The present discussion remains relative to optical fiber attenuation properties.

Q38. Define attenuation.

Absorption.

Absorption is a major cause of signal loss in an optical fiber. **Absorption** is defined as the portion of attenuation resulting from the conversion of optical power into another energy form, such as heat. Absorption in optical fibers is explained by three factors:

- Imperfections in the atomic structure of the fiber material
- The intrinsic or basic fiber-material properties
- The extrinsic (presence of impurities) fiber-material properties

Imperfections in the atomic structure induce absorption by the presence of missing molecules or oxygen defects. Absorption is also induced by the diffusion of hydrogen molecules into the glass fiber. Since intrinsic and extrinsic material properties are the main cause of absorption, they are discussed further.

Intrinsic Absorption.—Intrinsic absorption is caused by basic fiber-material properties. If an optical fiber were absolutely pure, with no imperfections or impurities, then all absorption would be intrinsic. Intrinsic absorption sets the minimal level of absorption. In fiber optics, silica (pure glass) fibers are used predominately. Silica fibers are used because of their low intrinsic material absorption at the wavelengths of operation.

In silica glass, the wavelengths of operation range from 700 nanometers (nm) to 1600 nm. Figure 2-22 shows the level of attenuation at the wavelengths of operation. This wavelength of operation is between two intrinsic absorption regions. The first region is the ultraviolet region (below 400-nm wavelength). The second region is the infrared region (above 2000-nm wavelength).

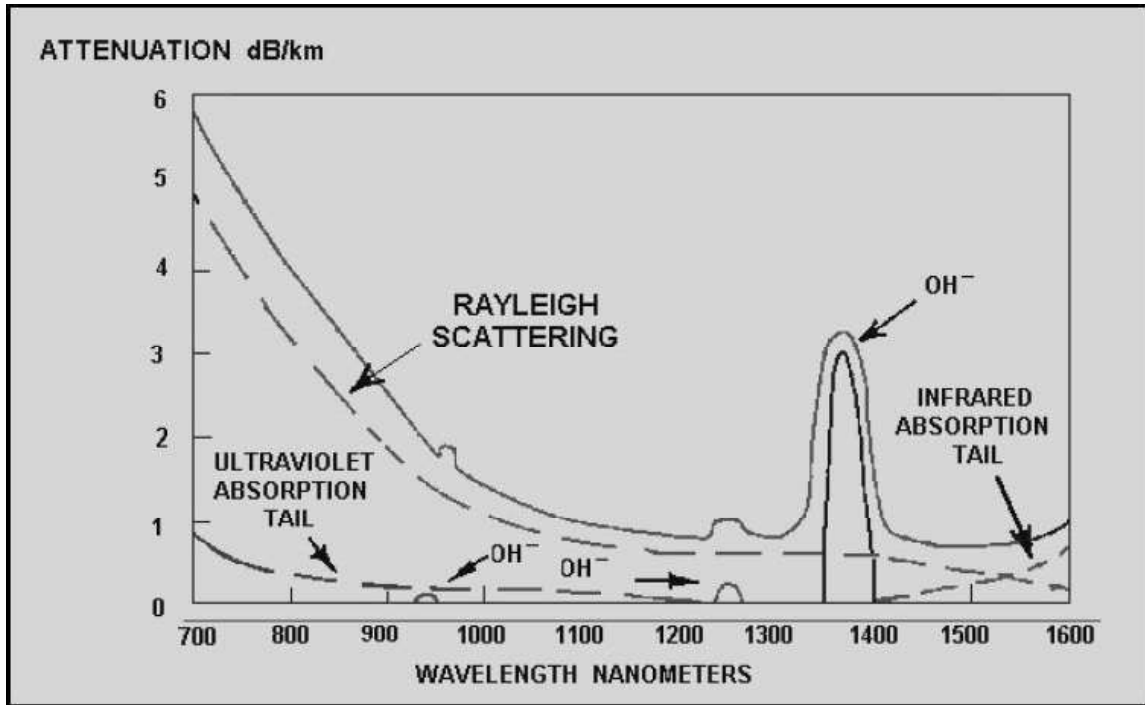

Figure 2-22. - Fiber losses.

Intrinsic absorption in the ultraviolet region is caused by electronic absorption bands. Basically, absorption occurs when a light particle (photon) interacts with an electron and excites it to a higher energy level. The tail of the ultraviolet absorption band is shown in figure 2-22.

The main cause of intrinsic absorption in the infrared region is the characteristic vibration frequency of atomic bonds. In silica glass, absorption is caused by the vibration of silicon-oxygen (Si-O) bonds. The interaction between the vibrating bond and the electromagnetic field of the optical signal causes intrinsic absorption. Light energy is transferred from the electromagnetic field to the bond.

Extrinsic Absorption.—Extrinsic absorption is caused by impurities introduced into the fiber material. Trace metal impurities, such as iron, nickel, and chromium, are introduced into the fiber during fabrication. **Extrinsic absorption** is caused by the electronic transition of these metal ions from one energy level to another.

Extrinsic absorption also occurs when hydroxyl ions (OH⁻) are introduced into the fiber. Water in silica glass forms a silicon-hydroxyl (Si-OH) bond. This bond has a

fundamental absorption at 2700 nm. However, the harmonics or overtones of the fundamental absorption occur in the region of operation. These harmonics increase extrinsic absorption at 1383nm, 1250nm, and 950nm. Figure 2-22 shows the presence of the three OH⁻ harmonics. The level of the OH⁻ harmonic absorption is also indicated.

These absorption peaks define three regions or windows of preferred operation. The first window is centered at 850nm. The second window is centered at 1300nm. The third window is centered at 1550nm. Fiber optic systems operate at wavelengths defined by one of these windows.

The amount of water (OH⁻) impurities present in a fiber should be less than a few parts per billion. Fiber attenuation caused by extrinsic absorption is affected by the level of impurities (OH⁻) present in the fiber. If the amount of impurities in a fiber is reduced, then fiber attenuation is reduced.

Q39. What are the main causes of absorption in optical fiber?

Q40. Silica (pure glass) fibers are used because of their low intrinsic material absorption at the wavelengths of operation. This wavelength of operation is between two intrinsic absorption regions. What are these two regions called? What are the wavelengths of operation for these two regions?

Q41. Extrinsic (OH⁻) absorption peaks define three regions or windows of preferred operation. List the three windows of operation.

Scattering

Basically, scattering losses are caused by the interaction of light with density fluctuations within a fiber. Density changes are produced when optical fibers are manufactured. During manufacturing, regions of higher and lower molecular density areas, relative to the average density of the fiber, are created. Light traveling through the fiber interacts with the density areas as shown in figure 2-23. Light is then partially scattered in all directions.

In commercial fibers operating between 700nm and 1600nm wavelength, the main source of loss is called Rayleigh scattering. Rayleigh scattering is the main loss mechanism between the ultraviolet and infrared regions as shown in figure 2-22. Rayleigh scattering occurs when the size of the density fluctuation (fiber defect) is less than one-tenth of the operating wavelength of light. Loss caused by Rayleigh scattering is proportional to the fourth power of the wavelength ($1/\lambda^4$). As the wavelength increases, the loss caused by Rayleigh scattering decreases.

If the size of the defect is greater than one-tenth of the wavelength of light, the scattering mechanism is called Mie scattering. Mie scattering, caused by these large defects in the fiber core, scatters light out of the fiber core. However, in commercial fibers, the effects of Mie scattering are insignificant. Optical fibers are manufactured with very few large defects.

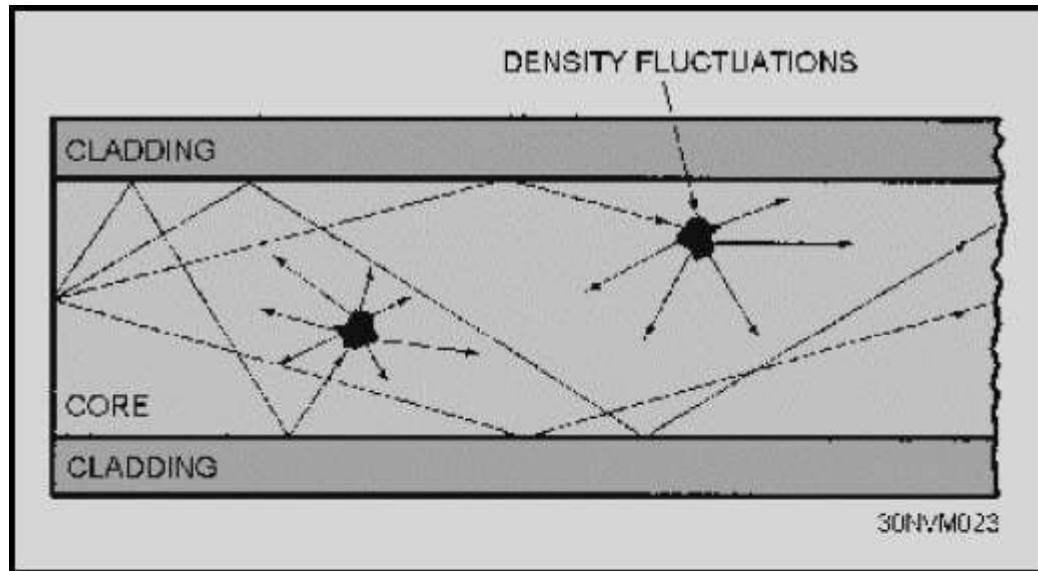

Figure 2-23. - Light scattering

Q42. What is the main loss mechanism between the ultraviolet and infrared absorption regions?

Q43. Scattering losses are caused by the interaction of light with density fluctuations within a fiber. What are the two scattering mechanisms called when the size of the density fluctuations is (a) greater than and (b) less than one-tenth of the operating wavelength?

Bending Loss

Bending the fiber also causes attenuation. Bending loss is classified according to the bend radius of curvature: microbend loss or macrobend loss. Microbends are small microscopic bends of the fiber axis that occur mainly when a fiber is cabled. Macrobends are bends having a large radius of curvature relative to the fiber diameter. Microbend and macrobend losses are very important loss mechanisms. Fiber loss caused by microbending can still occur even if the fiber is cabled correctly. During installation, if fibers are bent too sharply, macrobend losses will occur.

Microbend losses are caused by small discontinuities or imperfections in the fiber. Uneven coating applications and improper cabling procedures increase microbend loss.

External forces are also a source of microbends. An external force deforms the cabled jacket surrounding the fiber but causes only a small bend in the fiber. Microbends change the path that propagating modes take, as shown in figure 2-24. Microbend loss increases attenuation because low-order modes become coupled with high-order modes that are naturally lossy.

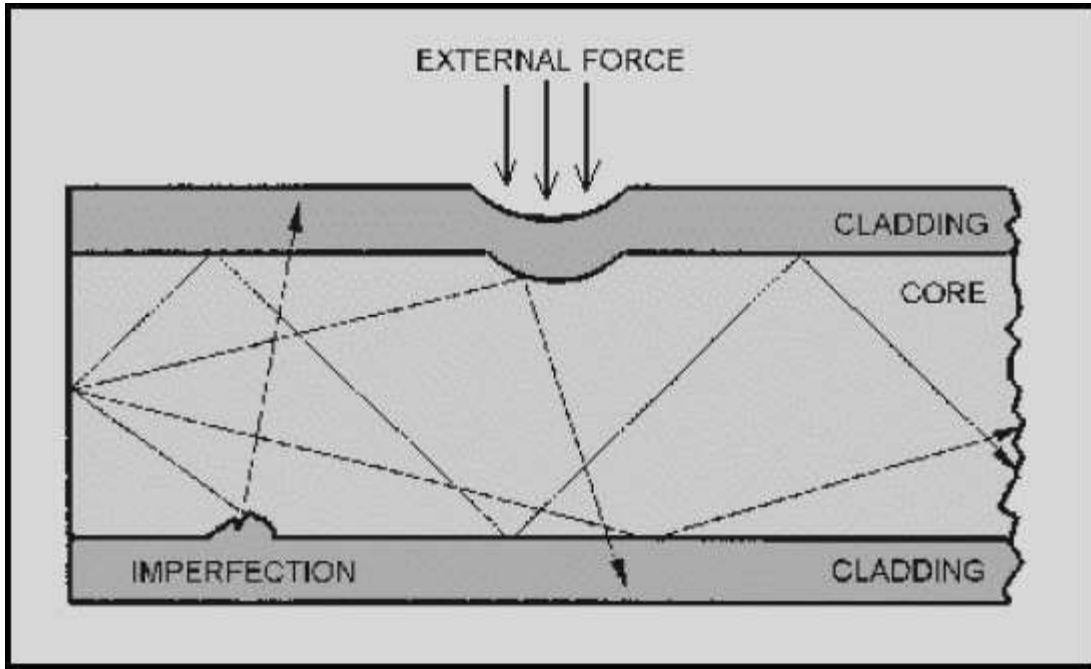

Figure 2-24. - Microbend loss

Macrobend losses are observed when a fiber bend's radius of curvature is large compared to the fiber diameter. These bends become a great source of loss when the radius of curvature is less than several centimeters. Light propagating at the inner side of the bend travels a shorter distance than that on the outer side. To maintain the phase of the light wave, the mode phase velocity must increase. When the fiber bend is less than some critical radius, the mode phase velocity must increase to a speed greater than the speed of light. However, it is impossible to exceed the speed of light. This condition causes some of the light within the fiber to be converted to high-order modes. These high-order modes are then lost or radiated out of the fiber.

Fiber sensitivity to bending losses can be reduced. If the refractive index of the core is increased, then fiber sensitivity decreases. Sensitivity also decreases as the diameter of the overall fiber increases. However, increases in the fiber core diameter increase fiber sensitivity. Fibers with larger core size propagate more modes. These additional modes tend to be more lossy.

Q44. Microbend loss is caused by microscopic bends of the fiber axis. List three sources of microbend loss.

Q45. How is fiber sensitivity to bending losses reduced?

DISPERSION

Is the spreading of a pulse of light as it travels down the length of an optical fiber. Dispersion limits the bandwidth or information carrying capacity of a fiber. The bit rate must be low enough to ensure that pulses do not overlap. A lower bit rate means that the pulses are farther apart and, therefore, that greater dispersion can be tolerated. There are five types of dispersion:

1. Modal dispersion
2. Material dispersion
3. Waveguide dispersion
4. Chromatic dispersion
5. Polarization mode dispersion

Modal Dispersion

Modal dispersion occurs only in multimode fibers. It is the result of light rays following different paths through the fiber core and consequently arrives at the fiber end at different times. The input light pulse is made up of a group of modes. As the modes propagate along the fiber, light energy distributed among the modes is delayed by different amounts. The pulse spreads because each mode propagates along the fiber at different speeds. Since modes travel in different directions, some modes travel longer distances. Modal dispersion occurs because each mode travels a different distance over the same time span, as shown in figure 2-25. The modes of a light pulse that enter the fiber at one time exit the fiber a different times. This condition causes the light pulse to spread. As the length of the fiber increases, modal dispersion increases.

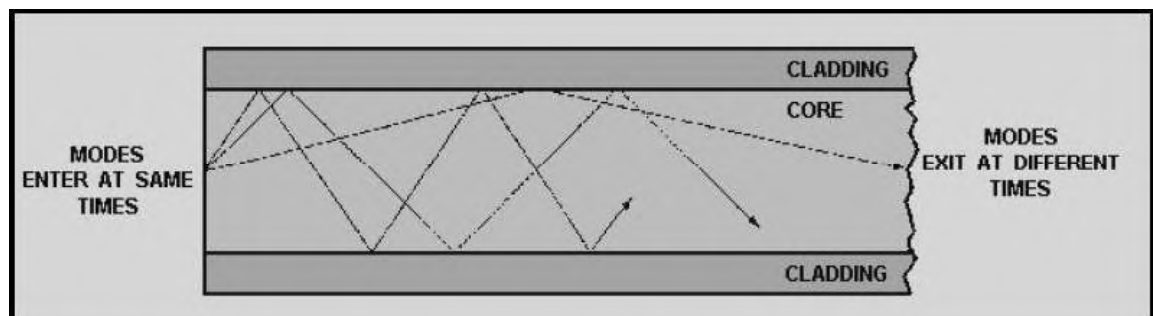

Figure 2-25. - Distance traveled by each mode over the same time span

Material Dispersion

Material dispersion occurs because different wavelengths (colors) also travel at different velocities through a fiber, even in the same mode. Remember, $n = c/v$ where “c”

is the speed of light in a vacuum and “v” is the speed of the same wavelength in a material. Here the index of refraction will change according to the wavelength. Material dispersion occurs because the spreading of a light pulse is dependent on the wavelengths' interaction with the refractive index of the fiber core. Different wavelengths travel at different speeds in the fiber material. Different wavelengths of a light pulse that enter a fiber at one time exit the fiber at different times. Material dispersion is a function of the source spectral width. The spectral width specifies the range of wavelengths that can propagate in the fiber. Material dispersion is less at longer wavelengths.

The amount of dispersion depends on two factors:

1. The range of wavelengths injected into the fiber. A source does not emit a single wavelength; it emits several. The range of wavelengths, expressed in nanometers, is the spectral width of the source. An LED can have a spectral width in the range of 35nm to well over 100nm. A Laser diodes spectral width is .1nm to 3nm.

2. Longer “reddish” wavelengths travel faster than shorter “bluish” wavelengths. An 860nm wavelength travels faster than an 840nm wavelength. At 1550nm, the situation is reversed. The shorter wavelength travels faster than longer ones: a 1560nm wavelength travels slower than a 1540nm wavelength. At some point a crossover must occur where the bluish and reddish wavelengths travel at the same speed. This point is called the zero dispersion point occurs at 1300nm.

Material dispersion is of greater concern in single-mode systems. A standard single-mode fiber has the lowest material dispersion at 1300nm and the lowest loss at 1550nm. Or, it has the highest information-carrying capacity at 1300nm and the longer transmission distance at 1550nm. Dispersion is about five times higher at 1550nm than at 1300nm, while attenuation is about 0.2 dB lower.

A dispersion-shifted fiber attempts to give the designer the best of both worlds, low loss and high bandwidth at the same optical wavelength. The zero-dispersion wavelength is shifted from the 1300nm region to 1550nm.

Zero dispersion-shifted (DS) fibers have the zero dispersion point shifted to 1550nm to coincide with the low attenuation operating point. Material dispersion is reduced to zero. DS fibers work well when a single channel data stream is transmitted through the fiber. The newer systems send more than one channel through the fiber. They may send channels or streams of data at 1546, 1548, 1550, and 1552nm. Here an effect called four-wave mixing robs the signals of power and increase noise in the system. Four-wave mixing occurs in fibers that have the zero dispersion point at or near the wavelengths being transmitted. This mixing can seriously limit the use of multiple wavelengths in DWDM applications and this will lower transmission speeds.

Adding a small amount of dispersion can suppress four-wave mixing. Nonzero-dispersion-shifted (NZ-DS) fibers overcome this problem by shifting the zero dispersion point not to 1550nm, but to a point nearby. NZ-DS fibers, because of their ability to

handle high data rates and multiple wavelengths, are widely used in communications applications, surpassing DS fibers.

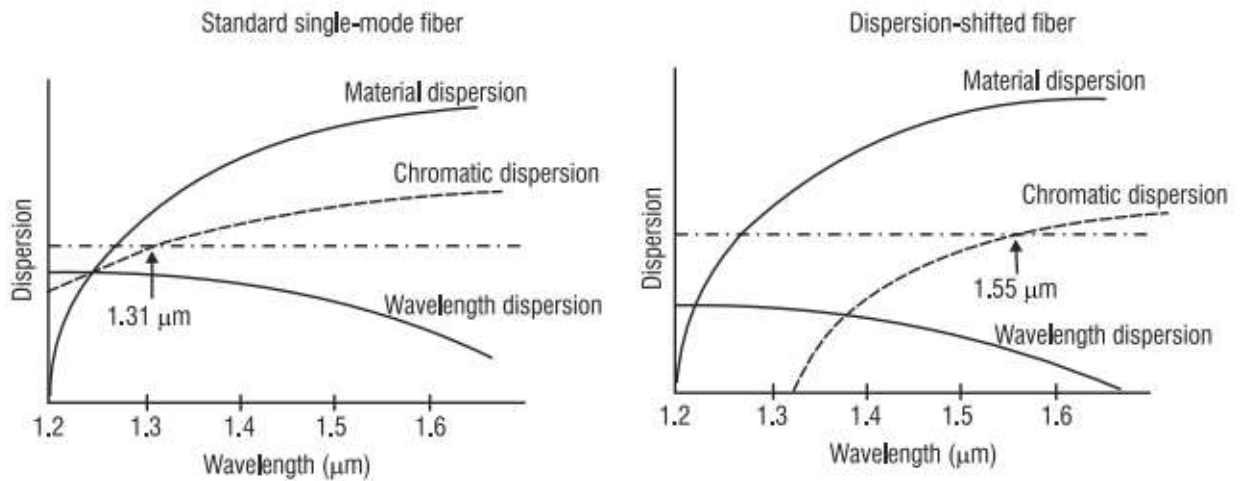

Waveguide Dispersion

Waveguide dispersion occurs because the mode propagation constant (β) is a function of the size of the fiber's core relative to the wavelength of operation. Waveguide dispersion is most significant in a single-mode fiber. The energy level travels at slightly different velocities in the core and cladding because of the slightly different refractive indices of the materials. Altering the internal structure of the fiber allows waveguide dispersion to be substantially changed, thus changing the specified overall dispersion of the fiber. About 80% of the light is propagated down the core with the remaining 20% traveling down the cladding.

To understand the physical origin of waveguide dispersion, we need to know that the light energy of a mode propagates partly in the core and partly in the cladding and that the effective index of a mode lies between the refractive indices of the cladding and the core. The actual value of the effective index between these two limits depends on the proportion of power that is contained in the cladding and the core. If most of the power is contained in the core, the effective index is closer to the core refractive index. If most of the power propagates in the cladding, the effective index is closer to the cladding refractive index.

The power distribution of a mode between the core and the cladding of a fiber is itself a function of the wavelength. More accurately, the longer the wavelength, the more power in the cladding. Thus, even in the absence of material dispersion, the refractive indices of the core and the cladding are independent of wavelength. If the wavelength changes, the power distribution changes.

Chromatic Dispersion (CD)

Chromatic Dispersion (CD) is the term given to the phenomenon by which different spectral components of a light pulse travel at different speeds. CD arises for two reasons. The first reason is that the refractive index of silica is frequency dependent. Thus different frequency components travel at different speeds in silica. This component of CD is called material Dispersion. The second reason is that although material dispersion is the principle component of chromatic dispersion for most fibers, there is a second component called Waveguide Dispersion.

Polarization Mode Dispersion (PMD)

Polarization mode dispersion (PMD) is a minor type of dispersion that only becomes significant in a system that has already minimized other forms of dispersion and that is operating at gigabit data rates. Polarization mode dispersion arises from the fact that even a single mode can have two polarization states. These polarizations travel at slightly different speeds, thus spreading the signal. For a 100-km transmission distance, PMD limits the signal frequency to 40 GHz. The magnitude of PMD in a fiber is expressed as this difference, which is known as the differential group delay (DGD) and called $\Delta\tau$ ("delta Tau").

Each type of dispersion mechanism leads to pulse spreading. As a pulse spreads, energy is overlapped. This condition is shown in figure 2-26. The spreading of the optical pulse as it travels along the fiber limits the information capacity of the fiber.

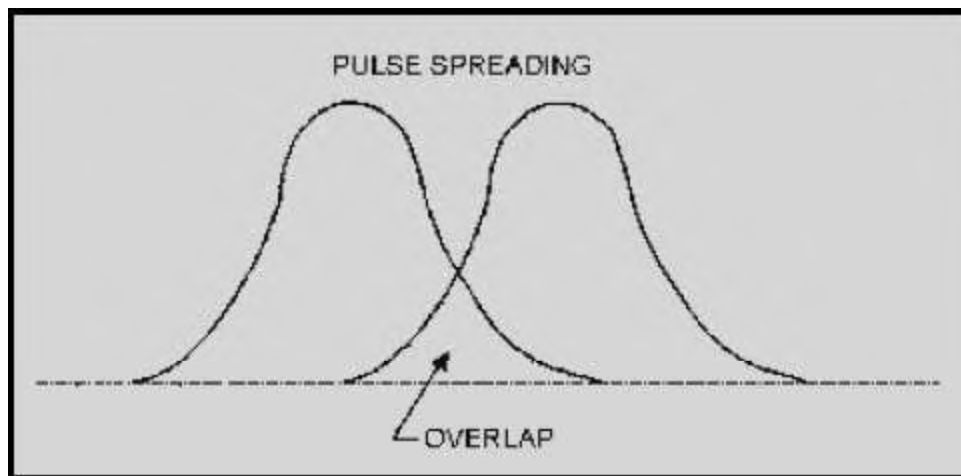

Figure 2-26. - Pulse overlap

In multimode fibers, waveguide dispersion and material dispersion are basically separate properties. Multimode waveguide dispersion is generally small compared to material dispersion. Waveguide dispersion is usually neglected. However, in single mode fibers, material and waveguide dispersion are interrelated. The total dispersion present in single mode fibers may be minimized by trading material and waveguide properties depending on the wavelength of operation.

Q46. Name the five types of dispersion.

Q47. Which dispersion mechanism (material or waveguide) is a function of the size of the fiber's core relative to the wavelength of operation?

Modal dispersion is the dominant source of dispersion in multimode fibers. Modal dispersion does not exist in single mode fibers. Single mode fibers propagate only the fundamental mode. Therefore, single mode fibers exhibit the lowest amount of total dispersion. Single mode fibers also exhibit the highest possible bandwidth.

Q48. Modes of a light pulse that enter the fiber at one time exit the fiber at different times. This condition causes the light pulse to spread. What is this condition called?

SUMMARY

Now that you have completed this chapter, let's review some of the new terms, concepts, and ideas that you have learned. You should have a thorough understanding of these principles before moving on to chapter 3.

A **LIGHTWAVE** is a form of energy that is moved by wave motion.

WAVE MOTION is defined as a recurring disturbance advancing through space with or without the use of a physical medium.

SCIENTIFIC EXPERIMENTS seem to show that light is composed of tiny particles, while other experiments indicate that light is made up of waves. Today, physicists have come to accept a theory concerning light that is a combination of particle (ray) theory and wave (mode) theory.

TRANSVERSE WAVE MOTION describes the up and down wave motion that is at right angle (transverse) to the outward motion of the waves.

LIGHT RAYS, when they encounter any substance, are either transmitted, refracted, reflected, or absorbed.

REFLECTION occurs when a wave strikes an object and bounces back (toward the source). The wave that moves from the source to the object is called the **incident wave**, and the wave that moves away from the object is called the **reflected wave**.

The **LAW OF REFLECTION** states that the angle of incidence is equal to the angle of reflection.

REFRACTION occurs when a wave traveling through two different mediums passes through the **boundary** of the mediums and bends toward or away from the **normal**.

The **RAY THEORY** and the **MODE THEORY** describe how light energy is transmitted along an optical fiber.

The **INDEX OF REFRACTION** is the basic optical material property that measures the speed of light in an optical medium.

SNELL'S LAW OF REFRACTION describes the relationship between the incident and the refracted rays when light rays encounter the boundary between two different transparent materials.

TOTAL INTERNAL REFLECTION occurs when light rays are totally reflected at the boundary between two different transparent materials. The angle at which total internal reflection occurs is called the **critical angle of incidence**.

The **CORE, CLADDING,** and **COATING** or **BUFFER** are the three basic parts of an optical fiber.

The **RAY THEORY** describes how light rays propagate along an optical fiber. **MERIDIONAL RAYS** pass through the axis of the optical fiber. **SKEW RAYS** propagate through an optical fiber without passing through its axis.

BOUND RAYS propagate through an optical fiber core by total internal reflection. **UNBOUND RAYS** refract out of the fiber core into the cladding and are eventually lost.

The **ACCEPTANCE ANGLE** is the maximum angle to the axis of the fiber that light entering the fiber is bound or propagated. The light ray incident on the fiber core must be within the acceptance cone defined by the acceptance angle to be propagated along an optical fiber.

NUMERICAL APERTURE (NA) is a measurement of the ability of an optical fiber to capture light.

The **MODE THEORY** uses electromagnetic wave behavior to describe the propagation of light along an optical fiber. A set of guided electromagnetic waves are called the **modes** of the fiber.

MODES traveling in an optical fiber are said to be transverse. Modes are described by their electric, $E(x,y,z)$, and magnetic, $H(x,y,z)$, fields. The electric field and magnetic field are at right angles to each other.

NORMALIZED FREQUENCY determines how many modes a fiber can support. The number of modes is represented by the normalized frequency constant.

SINGLE MODE and **MULTIMODE FIBERS** are classified by the number of modes that propagate along the optical fiber. Single mode fibers propagate only one mode because the core size approaches the operational wavelength. Multimode fibers can propagate over 100 modes depending on the core size and numerical aperture.

ATTENUATION is the loss of optical power as light travels along an optical fiber. Attenuation in an optical fiber is caused by absorption, scattering, and bending losses.

DISPERSION spreads the optical pulse as it travels along the fiber. Dispersion limits how fast information is transferred.

ABSORPTION is the conversion of optical power into another energy form, such as heat. **INTRINSIC ABSORPTION** is caused by basic fiber-material properties. **EXTRINSIC ABSORPTION** is caused by impurities introduced into the fiber material.

SILICA FIBERS are predominately used in fiber optic communications. They have low intrinsic material absorption at the wavelengths of operation.

The **WAVELENGTH OF OPERATION** in fiber optics is between 700 nm and 1600 nm. The wavelength of operation is between the ultraviolet (below 400 nm) and infrared (above 2000 nm) intrinsic absorption regions.

EXTRINSIC ABSORPTION occurs when impurities, such as hydroxyl ions (OH⁻), are introduced into the fiber. OH⁻ absorption peaks define three regions or windows of preferred operation. The first window is centered at 850 nm. The second window is centered at 1300 nm. The third window is centered at 1550 nm.

SCATTERING losses are caused by the interaction of light with density fluctuations within a fiber. **Rayleigh scattering** is the main source of loss in commercial fibers operating between 700 nm and 1600 nm.

MICROBENDS are small microscopic bends of the fiber axis that occur mainly when a fiber is cabled. **MACROBENDS** are bends having a large radius of curvature relative to the fiber diameter.

CHROMATIC DISPERSION occurs because light travels through different materials and different waveguide structures at different speeds. **MATERIAL DISPERSION** is dependent on the light wavelengths interaction with the refractive index of the core. **WAVEGUIDE DISPERSION** is a function of the size of the fiber's core relative to the wavelength of operation.

MODAL DISPERSION occurs because each mode travels a different distance over the same time span.

ANSWERS TO QUESTIONS Q1. THROUGH Q48.

- A1. *Photons.*
- A2. *Transverse-wave motion.*
- A3. *Light waves are either transmitted, refracted, reflected, or absorbed.*
- A4. *Transparent.*
- A5. *Opaque.*
- A6. *The law of reflection states that the angle of incidence is equal to the angle of reflection.*
- A7. *When the wave is nearly parallel to the reflecting surface.*
- A8. *When the wave is perpendicular to the reflecting surface.*
- A9. *The law of reflection.*
- A10. *Depends on the bending caused by the velocity difference of the wave traveling through different mediums.*
- A11. *Transmitted.*
- A12. *Diffusion.*
- A13. *The ray theory and the mode theory.*
- A14. *The index of refraction.*
- A15. *Light will travel faster in an optical material that is less dense.*
- A16. *Part of the light ray is reflected back into the glass and part of the light ray is refracted (bent) as it enters the air.*
- A17. *Total internal reflection occurs when the angle of refraction approaches 90 degrees. This condition occurs when the angle of incidence increases to the point where no refraction is possible.*

- A18. *Critical angle of incidence.*
- A19. *Core, cladding, and coating or buffer.*
- A20. *Core.*
- A21. *The ray theory.*
- A22. *Total internal reflection.*
- A23. *Smaller.*
- A24. *NA measures the light-gathering ability of an optical fiber.*
- A25. *Skew ray angle.*
- A26. *Modes of the fiber.*
- A27. *Direction, amplitude, and wavelength of propagation.*
- A28. *Yes, the wave front will disappear because the total amount of phase collected must be an integer multiple of 2π . (If the propagating wave fronts are out of phase, they will disappear. The wave fronts that are in phase interfere with the wave fronts out of phase. This type of interference is called destructive interference.)*
- A29. *Cutoff wavelength.*
- A30. *Multimode fiber.*
- A31. *The order of a mode is indicated by the number of field maxima within the core of the fiber. The order of a mode is also determined by the angle that the wave front makes with the axis of the fiber.*
- A32. *Mode coupling is the exchange of power between two modes.*
- A33. *Increase.*
- A34. *$V \leq 2.405$.*
- A35. *Decrease.*
- A36. *OM1, OM2, OM3, OM4*

- A37. *Light absorption, scattering, and bending losses.*
- A38. *Attenuation is the loss of optical power as light travels along the fiber.*
- A39. *Intrinsic and extrinsic material properties.*
- A40. *Ultraviolet absorption region (below 400 nm) and infrared absorption region (above 2000 nm).*
- A41. *The first, second, and third windows of operation are 850 nm, 1300 nm, and 1550 nm, respectively.*
- A42. *Rayleigh scattering.*
- A43. *(a) Mie scattering; (b) Rayleigh scattering.*
- A44. *Uneven coating applications, improper cabling procedures, and external force.*
- A45. *Fiber sensitivity to bending losses can be reduced if the refractive index of the core is increased and/or if the overall diameter of the fiber increases.*
- A46. *Modal, Material, waveguide, chromatic, and polarization mode.*
- A47. *Waveguide dispersion.*
- A48. *Modal dispersion.*